

LONWORKS®

Router

User's Guide

Revision 3



ECHELON®
Corporation

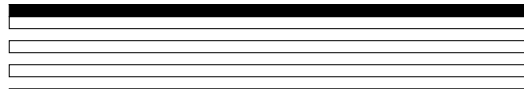

078-0018-01D

No part of this publication may be reproduced, stored in a retrieval system, or transmitted, in any form or by any means, electronic, mechanical, photocopying, recording, or otherwise, without the prior written permission of Echelon Corporation.

Echelon, LON, LONWORKS, LonBuilder, LonManager, LonTalk, LonUsers, Neuron, 3120, 3150, and the Echelon logo are trademarks of Echelon Corporation registered in the United States and other countries. LonLink, LONMARK, LonSupport, LonMaker, the LONMARK logo, and the LonUsers logo are trademarks of Echelon Corporation.

Document No. 79100

Printed in the United States of America.
Copyright ©1992 - 1995 by Echelon Corporation

Echelon Corporation
4015 Miranda Avenue
Palo Alto, CA, 94304, USA

FCC NOTICE

Note: This equipment has been tested and found to comply with the limits for a Class A digital device, pursuant to Part 15 of the FCC Rules. These limits are designed to provide reasonable protection against harmful interference when the equipment is operated in a commercial environment. This equipment generates, uses, and can radiate radio frequency energy and, if not installed and used in accordance with the instruction manual, may cause harmful interference to radio communications. However, there is no guarantee that interference will not occur in a particular installation. Operation of this equipment in a residential area is likely to cause harmful interference in which case the user will be required to correct the interference at his own expense.

Caution: Changes or modifications not covered in this manual must be approved in writing by the manufacturer's Regulatory Engineering department. Changes or modifications made without written approval may void the user's authority to operate this equipment.

VDE NOTICE

This product complies with VDE 0870 Part 30 as a peripheral device. To ensure continued compliance, this product should only be used in conjunction with other compliant devices.

CANADIAN DOC NOTICE

This digital apparatus does not exceed the Class A limits for radio noise emissions from digital apparatus set out in the Radio Interference Regulations of the Canadian Department of Communications.

Le présent appareil numérique n'émet pas de bruits radioélectriques dépassant les limites applicables aux appareils numériques de la classe A prescrites dans le règlement sur la brouillage radioélectrique édicté par le Ministère des Communications du Canada.

Contents

	Notices	i
1	Introduction	1-1
	Audience	1-4
	Content	1-4
	Related Documentation	1-4
2	Theory of Operation	2-1
	LonTalk® Protocol Support for Routers	2-2
	Looping Topologies	2-2
	Power Line Routers	2-3
	Routing Algorithms	2-4
	Repeater	2-4
	Bridge	2-4
	Configured Router	2-4
	Learning Router	2-5
	Message Buffers	2-7
3	Packaged Router Overview	3-1
	Mechanical Description	3-2
	Switches, Indicators, and Connectors	3-3
	ESD Warning	3-4
4	RTR-10 Overview	4-1
	Mechanical Description	4-2
	RTR-10 Power Requirements	4-5
	Power Supply Decoupling and Filtering	4-5
	Low Voltage Protection	4-5
	Electrical Interface	4-5
	ACLK2, BCLK1, and BCLK2	4-7
	ACP[4..0] and BCP[4..0]	4-7
	~ASVC and ~BSVC	4-7
	AXID[4..0] and BXID[4..0]	4-7
	PKT	4-8
	~RESET	4-9
	~SERVICE	4-9
5	Developing a Router with the RTR-10 Module	5-1
	Overview	5-2
	Using Predefined Transceivers	5-2
	Using Custom Transceivers	5-4

6	RTR-10 Design Issues	6-1
	EMI Design Issues	6-2
	Designing Systems for EMC (Electromagnetic Compatibility)	6-2
	EMC Design Tips	6-2
	ESD Design Issues	6-3
	Designing Systems for ESD Immunity	6-3
7	Installing a Router	7-1
	Introduction	7-2
	Defining a Network Topology	7-2
	Attaching the Router to a Network	7-2
	Connecting Power	7-4
	Installing the Router on a Network	7-5
	Router Installation with Network Management Messages	7-6
	Router Installation with the LonMaker® Installation Tool	7-6
	Router Installation with the LonManager® API	7-6
	Router Installation with the LonBuilder® Developer's Workbench	7-7
	Testing Router Installation	7-8
	Building a Router Mounting Bracket	7-8
8	Network Management Messages	8-1
	Introduction	8-2
	Standard Messages	8-2
	Router Specific Messages	8-4
	Router Specific Network Management Messages	8-5
	Set Router Mode	8-5
	Group or Subnet Table Clear	8-5
	Group or Subnet Table Download	8-5
	Group Forward	8-6
	Subnet Forward	8-6
	Group No Forward	8-7
	Subnet No Forward	8-7
	Group or Subnet Table Report	8-7
	Router Status	8-8
	Far Side Escape Code	8-8
	Router Options Set with Write Memory	8-8
	Set Routing Algorithm	8-9
	Set Buffer Size	8-9
	Set Priority Output Buffer Queue Count	8-10
	Set Input and Non-Priority Buffer Queue Count	8-11
	Appendix A Communications Parameters	A-1
	Appendix B Software License and Patent Agreement	B-1

1

Introduction

LONWORKS Routers connect two communications channels, and route LonTalk messages between them. Routers connect two communication channels and route LonTalk® messages between them. They support the installation of both small and large networks with dozens to thousands of nodes.

The following figure illustrates a typical installation with free topology, power line, and 78kbps bus topology channels connected to a 1.25Mbps backbone twisted pair channel using three routers. Because of the routers, the applications on all six nodes in this example can communicate transparently as if they were installed on a common channel.

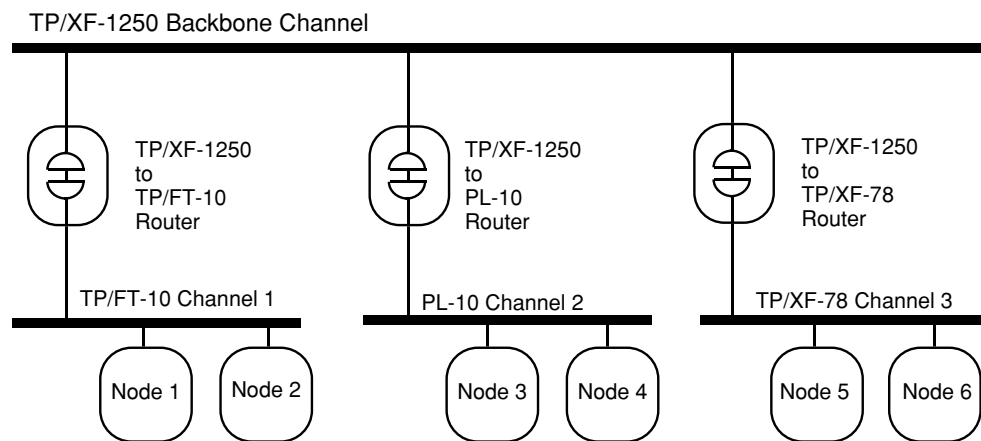

Figure 1.1 Sample Router Installation

Routers are used to:

- *Extend the limits of a single channel.* A router may be used to add a channel to a LONWORKS network to support additional nodes or extend the maximum channel length. Multiple routers may be added, depending on the capacity or distance needed.
- *Interface different communication media, or bit rates, in a LONWORKS network.* For example, it may be desirable to trade data rate for distance on portions of the network, or to use a 1.25Mbps backbone twisted pair channel to connect several 78kbps free topology and link power channels. Alternatively, it may be desirable to use power line for a portion of the network where the nodes are subject to frequent physical relocation, or if cable installation is difficult. In all of these cases, a router must be used to connect the dissimilar LONWORKS channels.
- *Enhance the reliability of the LONWORKS network.* The two channels connected to a router are physically isolated, so a failure on one channel does not affect the other. For example, in an industrial control network, isolation among connected cells may be desirable to prevent a failure in a single cell from bringing down multiple cells. This would be achieved by dedicating channels to individual cells and isolating them from one another with routers.
- *Improve overall network performance.* Routers can be used to isolate traffic within subsystems. For example, in a cluster of industrial cells, most of the communications may be with nodes within cells rather than across cells. Use of intelligent routers across cells will avoid forwarding messages addressed to nodes within a cell, thus increasing the capacity and decreasing the response time of the overall network.

The use of routers across channels is transparent to the application programs within nodes. Thus, application development can be done independently, without knowledge of the workings of the routers. Routers need to be taken into account only when determining the network image of a node. If a node is moved from one channel to another, only the network image must be changed. Network images are managed by a network services tool such as the LonManager® LonMaker® Installation Tool.

LONWORKS routers are offered in a variety of options so that they can be tailored for specific uses. Options include the following:

- *Integration.* Router components are available for embedding in OEM products. An RTR-10 router and two transceiver modules, one to handle each of two channels connected by the router, may be mounted on a motherboard, along with a power supply and two network connectors. This sub-assembly constitutes a custom router. It can be packaged in an enclosure to meet unique form factor and environmental requirements. Depending on the application, the package may contain a single router sub-assembly, or may include other application-specific hardware. See figure 1.2 for a block diagram of a router based on the RTR-10 router. Multiple routers may be packaged together for some applications, e.g., a backbone connecting multiple channels.

Packaged routers, FCC- and VDE-certified to comply with conducted and radiated emissions specifications and UL-certified for safety, with optional wall-mount power supplies, are also available from Echelon. These eliminate the need to build hardware and obtain the necessary electrical interference and safety certifications. Thus, they allow direct, off-the-shelf integration into the user's LONWORKS network.

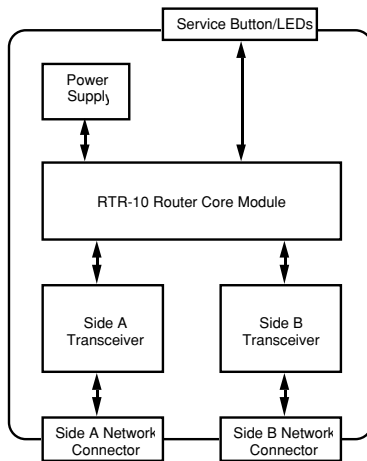

Figure 1.2 Router Assembly Using the Router Core Module

- *Routing Algorithm.* Routers can use one of four routing algorithms: *configured router*, *learning router*, *bridge*, or *repeater*. These options allow system performance to be traded for ease of installation. Configured and learning routers fall into a class of routers referred to as *intelligent routers*, which use routing intelligence to selectively forward messages based on the destination address. A bridge forwards all packets that match its domain(s). A repeater forwards all valid packets.

A network services tool such as the LonMaker Installation Tool is used to select the routing algorithm and calculate network topology as well as layer 4 timing parameters. Both sides of a router must use the same algorithm. LonBuilder®, LonMaker, or a tool based on the LonManager API is required to install a configured router.

Audience

The *LONWORKS Router User's Guide* provides user instructions for users of LONWORKS routers and for developers who plan to integrate the RTR-10 router into embedded or standalone routers.

Content

This manual provides detailed information about the hardware and firmware for LONWORKS routers.

- Chapter 1 introduces the LONWORKS routers.
- Chapter 2 discusses a theory of router operation and describes repeaters, bridges, configured routers, and learning routers.
- Chapter 3 provides an overview of the Model 71000 LONWORKS Router.
- Chapter 4 provides an overview of the Model 61000 RTR-10 Router Core module.
- Chapter 5 describes how to build a custom router using RTR-10 routers.
- Chapter 6 examines a number of design issues that should be considered when designing hardware based on the RTR-10 module.
- Chapter 7 lists installation instruction for routers.
- Chapter 8 describes network management services for routers.
- Appendix A lists the default communications parameters for LONWORKS routers.
- Appendix B includes a copy of the router software license and patent agreement.

Related Documentation

The following Echelon documents provide more information on the router:

- The *LonTalk Protocol* engineering bulletin summarizes the services available at each of the seven layers of the LonTalk protocol included with every Neuron® Chip.
- The *LonManager LonMaker Installation Tool User's Guide* describes how to install a router using the LonMaker Installation Tool.
- The *LonBuilder User's Guide* describes installing a router in a development network.
- The *LonManager Profiler User's Guide* describes how to import a router interface (.RIF) file to create a router type for LonMaker.
- The *LonManager API Programmer's Guide for DOS* and the *LonManager API Programmer's Guide for Windows* describe how to install a router using the LonManager API.

- The *Neuron Chip Data Book* describes the Neuron Chip. Descriptions cover CPUs, memory subsystems, LonTalk protocol, network communications port, programming model, application I/O, and additional functions.
- The *LONWORKS TPT Twisted Pair Transceiver Module User's Guide* describes the LONWORKS twisted pair transceivers. This is useful for the OEM implementing a router to interface with a twisted pair channel.
- The *LONWORKS FTT-10 Free Topology Transceiver User's Guide* describes the LONWORKS FTT-10 free topology transceiver. This is useful for the OEM implementing a router to interface with a TP/FT-10 free topology channel.
- The *LONWORKS LPT-10 Link Power Transceiver User's Guide* describes the LONWORKS LPT-10 link power transceiver. This is useful for the OEM implementing a router to interface with a link power channel.
- The *LONWORKS PLT-10A Transceiver User's Guide* describes the LONWORKS PLT-10A Power Line Transceiver. This is useful for the OEM implementing a router to interface with a PL-10 power line channel.
- The *LONWORKS PLT-20 Transceiver User's Guide* describes the LONWORKS PLT-20 Power Line Transceiver. This is useful for the OEM implementing a router to interface with a PL-20 power line channel.
- The *LONWORKS PLT-30 Transceiver User's Guide* describes the LONWORKS PLT-30 Power Line Transceiver. This is useful for the OEM implementing a router to interface with a PL-30 power line channel.
- The *Junction Box and Wiring Guidelines for Twisted Pair LONWORKS Networks* engineering bulletin describes the different types of junction boxes and interconnections that may be used in twisted-pair LONWORKS networks.
- The *LONWORKS Interoperability Guidelines* provide the guidelines that are the basis for obtaining the LONMARK™ logo, which indicates that a product is LONWORKS interoperable.

2

Theory of Operation

This chapter describes the router theory of operation. An overview is first presented of how the LonTalk protocol supports routers. This is followed by a discussion of looping topologies and how they are handled by routers. Then, routing algorithms are described, followed by a discussion of buffer usage within routers.

LonTalk Protocol Support for Routers

The LonTalk protocol is designed to provide transparent routing of messages between nodes that communicate via routers. To increase the efficiency of routers, the LonTalk protocol defines a hierarchical form of addressing using domain, subnet, and node addresses. Subnets do not cross intelligent routers, which allows intelligent routers to make a routing decision based on the subnet component of a node's logical address. To further facilitate the addressing of multiple dispersed nodes, the LonTalk protocol defines another class of addresses using domain and group addresses. Intelligent routers also can be configured to make a routing decision based on the group addressing component of a message.

In general, a network services tool such as the LonMaker Installation Tool, is responsible for domain, subnet, node, and group address assignments.

See the *LonTalk Protocol* engineering bulletin (005-0017-01) for a further description of the LonTalk protocol. See the *LONWORKS Installation Overview* (005-0006-01) for a further description of the installation scenarios.

Looping Topologies

A *looping topology* is a network topology that has the potential for message *loops*. A loop is a path through two or more routers that forwards a message from a channel back to the same channel. For example, figure 2.1 shows a looping topology with two channels and two routers. A message on channel A could be forwarded by router 1 to channel B, then the same message could be forwarded by router 2 back to channel A, starting an endless loop of forwarded messages.

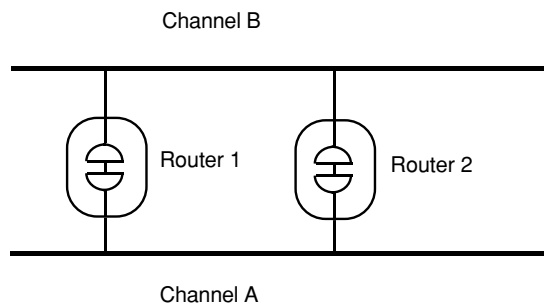

Figure 2.1 A Looping Topology

The LonTalk protocol does not support topologies where loops can occur. However, looping topologies may be desirable for the following reasons:

- *Increased Reliability.* Redundant routers may be used to increase system reliability by providing multiple paths between two channels.

- *Support for Open Media.* Open media such as RF may require redundant routers with overlapping coverage to ensure complete coverage of an area.

Configured routers can be used to support looping topologies, by configuring the routers to prevent message loops. For example, the topology in figure 2.1 can be supported if both routers are configured to forward all messages addressed to subnets on channel B from channel A; and all messages addressed to subnets on channel A from channel B. Any groups with members on both channels can only be forwarded by one of the two routers.

Network services tools such as the LonMaker Installation Tool or custom tools based on the LonManager API can automatically set up the forwarding tables for configured redundant routers.

Power Line Routers

A looping topology can be inadvertently created when using power line media. Passive coupling between different phases of a power line system can cause packets transmitted on one phase to be received by nodes installed on another phase. A loop can be formed when active coupling provided by a router is combined with passive coupling. Figure 2.2 illustrates an example looping topology.

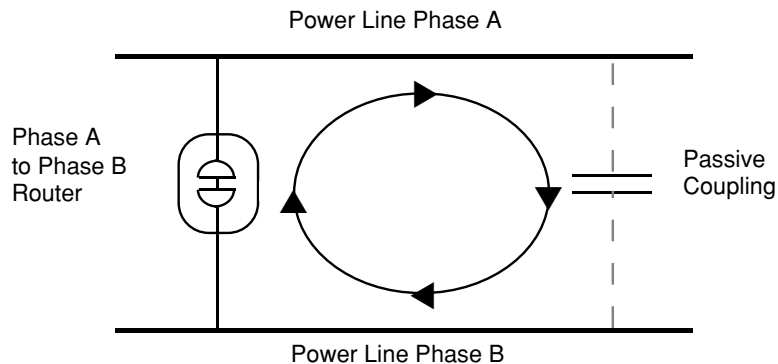

Figure 2.2 A Looping Topology with One Router

Routers can be used between power line channels only if the two channels are fully isolated. This is generally not the case between two phases on the same circuit, but may be the case between phases on different distribution transformers. Echelon's PLCA-10, PLCA-20, or PLCA-30 Power Line Communication Analyzers should be used to confirm isolation between power line channels before installing power line to power line routers.

Routing Algorithms

LONWORKS Routers can be installed to use one of four types of routing algorithms: *configured router*, *learning router*, *bridge*, and *repeater*. This selection allows system performance to be traded for ease of installation. The configured router and learning router algorithms are used to create *intelligent routers* that selectively forward messages based on network topology. This section describes the four algorithms. Both sides of a router must use the same routing algorithm.

The following general rules apply to all four routing algorithms:

- For a message to be forwarded, it must fit into the router's input and output message buffer. A free input message buffer must be available.
- For a message to be forwarded, it must have a valid CRC code.
- Priority messages are forwarded as priority messages, but with the priority level of the transmitting side rather than the priority level of the originator of the message. If the transmitting side has not been installed with a priority value, then priority messages are not forwarded in a priority slot. The priority message is still flagged as a priority message, so that if it passes through a second router that is installed with a priority level, the second router transmits the message in a priority slot.

Repeater

A *repeater* is a router which forwards all messages across in both directions, regardless of the destination or domain of the message. Any valid message (i.e. any message with a valid CRC code) received will be forwarded.

Bridge

A *bridge* is a router which forwards all messages received on either of the router's domains regardless of the message's destination. A bridge is used for spanning one or two domains.

Configured Router

A *configured router* is a router which forwards only messages received on either of the router's domains and which meet the forwarding rules described in figure 2.3. A *forwarding table* is used for each domain on each side of the router. Each forwarding table contains a *forwarding flag* for each of the 255 subnets and 255 groups in a domain. As described in figure 2.3, these flags determine whether or not a message should be forwarded or dropped based on the destination subnet or group address of the message.

The forwarding tables are initialized by a network services tool using the network management messages described in Chapter 8. By configuring the routing tables based on network topology, a network services tool can optimize network performance and make the most efficient use of available bandwidth. As described in the previous section, configured routers should be used for looping topologies.

There are two sets of forwarding tables, one in EEPROM and one in RAM. The EEPROM table is copied to the RAM table when the router is initially powered-up, after a reset, and when the router receives the *Set Router Mode* command with the *Initialize Routing Table* option. The RAM table is used for all forwarding decisions.

Several of the operations in figure 2.3 help prevent message loops for service pin messages. Service pin messages require special handling since they are broadcast to all nodes on the zero-length domain, and have a source subnet ID of zero. When a router receives a service pin message with a source subnet ID of zero, the router modifies the source subnet field of the message to be the router's subnet on the receiving side. If the receiving side is installed in two domains, two service pin messages are forwarded, one for each domain. This allows the router to drop the service pin message if a loop causes the message to be received again on the same side.

Learning Router

A *learning router* is a router which forwards only messages received on either of the router's domains and which meet the forwarding rules described in figure 2.2. Forwarding tables are used as with configured routers, except that the subnet forwarding tables are updated automatically by the router firmware, rather than being configured by a network services tool. The group forwarding tables are configured to always forward (flood) all messages with group destination addresses.

Learning routers learn network topology by examining the source subnet of all messages received by the router. Since subnets cannot span two channels connected to an intelligent router, the router can learn which side a subnet is on whenever that subnet ID appears in the source address.

The subnet forwarding tables are initially configured to forward all messages with subnet destination addresses. Each time a new subnet ID is observed in the source address field of a message, its corresponding flag is cleared (i.e., forwarding is disabled) in the subnet forwarding table. The forwarding flag for the destination address is then checked to determine whether the message should be forwarded or dropped. The forwarding flags are all cleared whenever the router is reset, so the learning process starts over after a reset.

The forwarding flag for a given subnet should never be cleared on both sides of a router. However, this may occur if a node is moved from one side of a router to the other side. For example, if subnet 1 is located on side A of a router, the router will learn subnet 1's location as soon as it receives a message generated by any node in subnet 1. If any subnet 1 node is moved to side B without reinstalling it, the router will learn that subnet 1 is also on side B, and will quit forwarding subnet 1 messages to side A. The router detects this error and logs it as described in Chapter 8.

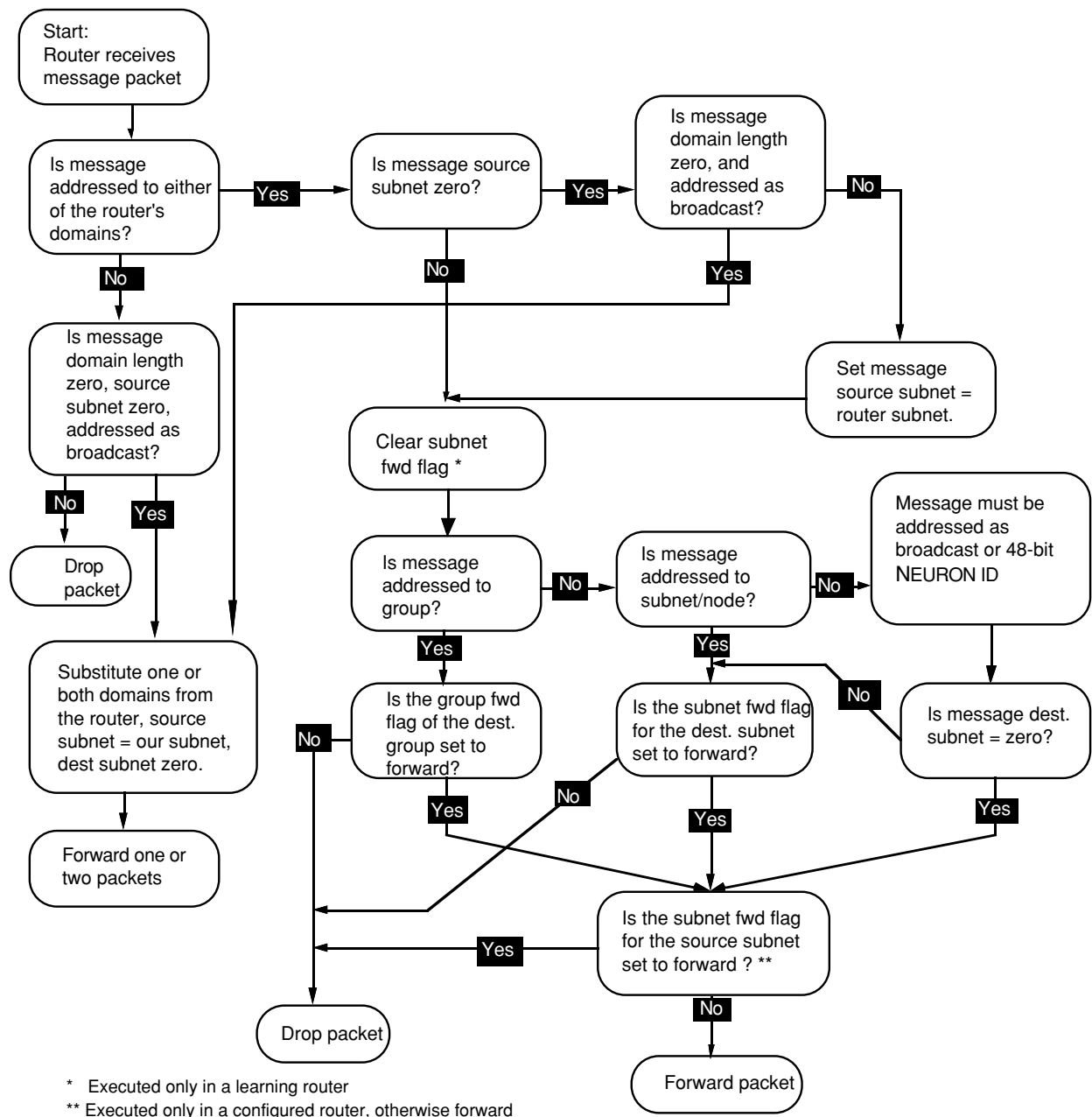

Figure 2.3 Configured/Learning Router Forwarding Rules

As with configured routers, learning routers sometimes modify source addresses for service pin messages to help prevent message loops.

Learning routers, in general, are less efficient in using channel bandwidth because they always forward all messages with group destination addresses. Their advantage is simplified installation since the installation tool does not need to know the network topology to configure a learning router.

Message Buffers

As messages are received by a router, they are placed in an input buffer queue. By default, this queue is limited to two message buffers to ensure that priority messages are never queued behind more than one non-priority message. When forwarded to the transmitting side of the router, priority messages have their own outgoing buffer queue. This assures priority processing of these outgoing messages since the transmitting side will send messages from the priority output buffer queue before sending messages from the non-priority output buffer queue. Figure 2.4 summarizes the message flow through the input and output buffer queues. This message flow is duplicated for messages moving in the opposite direction, i.e., another set of input and output buffer queues exist for messages flowing in the opposite direction.

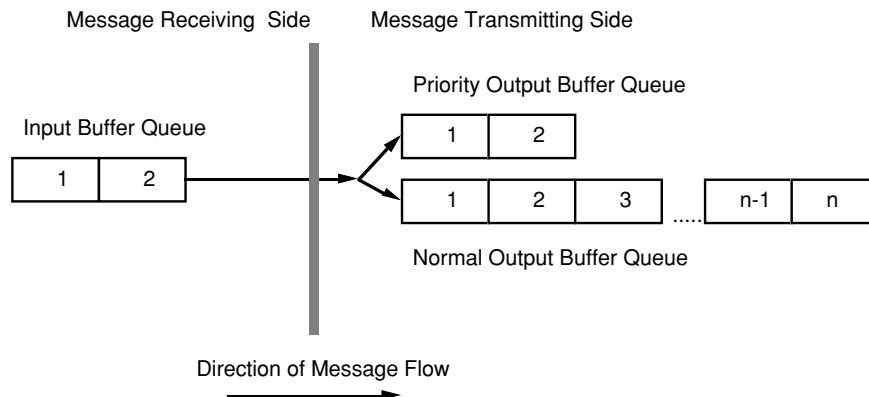

Figure 2.4 Buffering Scheme for a LONWORKS Router

The size and count of the message buffers is limited by the amount of RAM on the router. Each router side has 1,254 bytes of buffer space available. By default, this space is allocated as two input buffers, two priority output buffers, and 15 non-priority buffers. The default buffers are all 66 bytes, so the total RAM usage for the default buffers is:

Queue	Count	Size	Total Bytes
Input Buffer Queue	2	66	132
Priority Output Buffer Queue	2	66	132
Non-Priority Output Buffer Queue	15	66	<u>990</u>
TOTAL			1 2 5 4

The default size of 66 bytes allows the router to handle packets with maximum address overhead and data size for any network variable message and explicit messages with up to 40 bytes of data; this is large enough for any network management or network diagnostic message. In applications that must route large explicit messages with more than 40 bytes of data, the buffer size must be increased, and the count of non-priority buffers decreased. See Chapter 6 of the *Neuron C Programmer's Guide* to understand how the network buffer sizes are calculated. The size and count of buffers can be changed as described in Chapter 8 of this document. They also can be changed using the *NodeUtil* node utility available on the LonLink™ bulletin board and Internet Host. The total memory required by the three buffer queues must not exceed 1254 bytes.

The default buffer configuration places the bulk of the buffers on the output queues of the router. For example, the standard configuration places two network buffers on the input queue and 17 buffers on the output queue (2 priority and 15 non-priority) of each router side. The reasoning behind this configuration is to keep buffered packets on the output queues, after they have been processed for forwarding. This processing includes checking for priority packets. Priority packets are sensed and forwarded through the router's priority output buffers. This assures that priority packets are processed as quickly as possible, rather than allowing them to be delayed behind non-priority packages in a large input queue.

There are applications, however, where the network traffic may be 'bursty' where many packets appear on the network almost at the same time. In these cases the traffic bursts may cause the input queue to become full and loose the excess packets.

In this case it may be preferable to move more of the packet buffering from the output queue to the input queue. This can be done by increasing the size of the input queue and decreasing the size of the output queue. A router with a larger input queue can handle larger bursts of traffic, at the risk of priority messages being queued behind several non-priority messages.

3

Packaged Router Overview

This chapter provides an overview of the Model 71000 LONWORKS Router hardware. If you are using custom routers based on the RTR-10 Router Core Module, skip this chapter.

Mechanical Description

The following drawings provide the front and back views of the Model 71000 router.

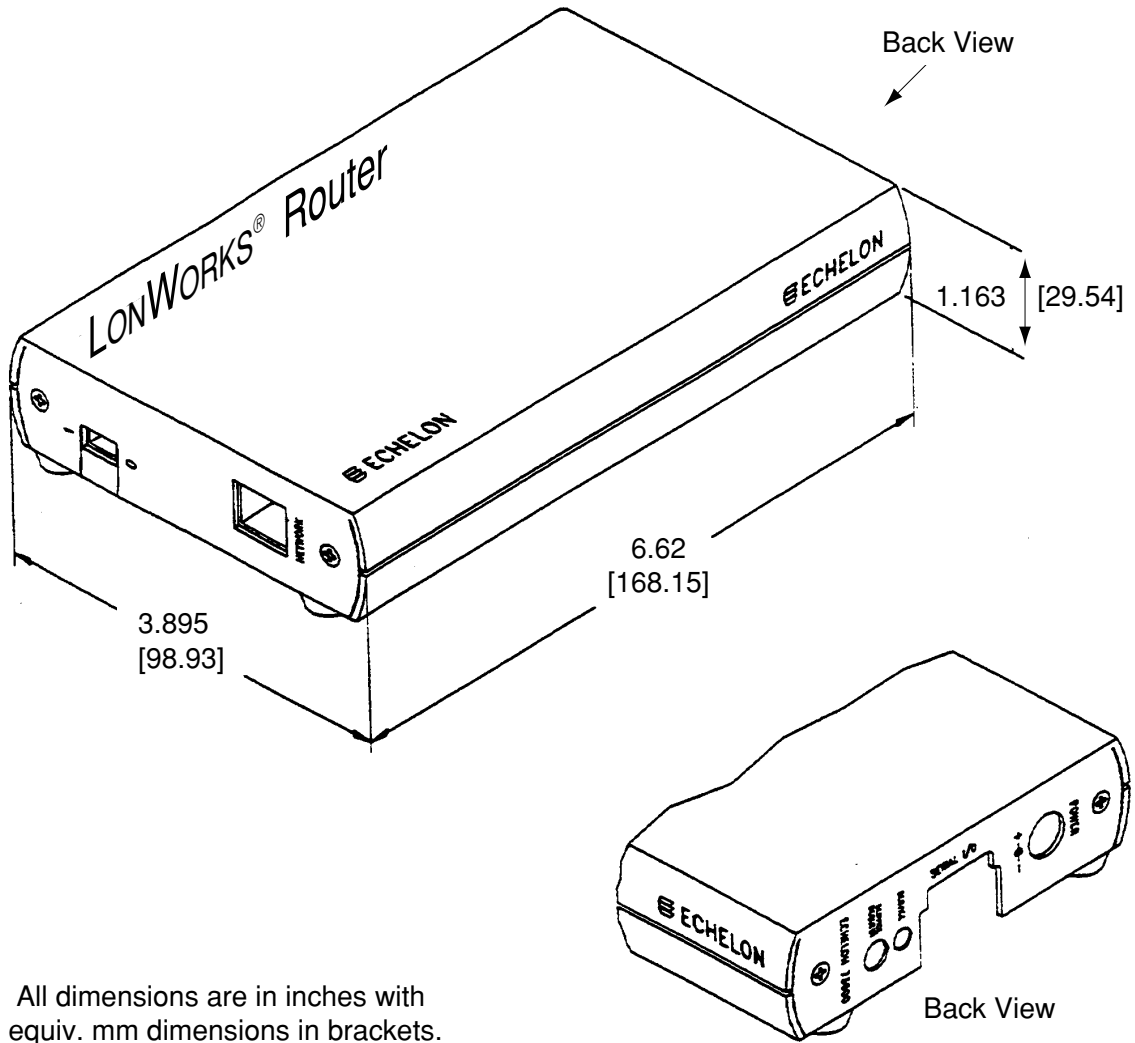

Figure 3.1 Router Views - Front and Back (rubber feet not included in the dimensions)

Switches, Indicators, and Connectors

Table 3.1 describes the function of router switches, indicators, and connectors.

Table 3.1 Router Interfaces

Interface	Function
Service Request	Pressing this switch grounds the service pin to both sides of the router. When this switch is pressed, both service LEDs should light to maximum intensity. This action generates service request messages from each side of the router. For more information, see the <i>Neuron Chip Data Book</i> .
Service 1	(Yellow LED) When the service request switch is being pressed, this LED is on at maximum intensity. If the service request switch is not being pressed, then the LED indicates the following: <i>on</i> an unrecovered error has been detected on side one <i>blinking</i> side one unconfigured; routing tables or router node address assignment have not been loaded <i>off</i> side one configured
Power On	(Green LED) Indicates that power is being supplied to the router. Does not necessarily indicate that the power supply voltage is within tolerance.
Status	(Green LED) Flickers when a packet is being forwarded in either direction. The rate of flashing can be used as a rough indicator of router activity level.
Service 2	(Yellow LED) When the service request switch is being pressed, this LED is on at maximum intensity. If the service request switch is not being pressed, then the LED indicates the following: <i>on</i> an unrecovered error has been detected on side two <i>blinking</i> side two unconfigured; routing tables or router node address assignment have not been loaded <i>off</i> side two configured

Table 3.1 Router Interfaces (*continued*)

<i>Interface</i>	<i>Function</i>
Power	Input connector for power supply.
Net 1	RJ-45 modular connector for connecting side one of the router to a twisted-pair channel.
Net 2	RJ-45 modular connector for connecting side two of the router to a twisted-pair channel.

ESD Warning

This product contains devices which are sensitive to static electricity. Before installing or removing network cables, touch earth ground with your hand to discharge any static electricity which may have accumulated.

4

RTR-10 Overview

This chapter provides an overview of the Model 61000 RTR-10 Router Core Module. If you are using the Model 71000 LONWORKS Router, skip this chapter.

Mechanical Description

The RTR-10 Router Core Module consists of a 67mm by 23mm by 7mm (2.65" by 0.9" by 0.3") module with the core electronics and firmware required to implement a router. The RTR-10 is attached to a motherboard, using a 40-position 0.050-inch spacing SIMM socket. Two compatible sockets are available:

- AMP 822021-1, MICRO-EDGE SIMM Vertical Connector with metal latches, 0.050 Centerline Single Row Connector - 40 position.
- AMP 4-382483-0, SIMM II Right Angle Connector, 0.050 Centerline Single Row Connector - 40 position.

Within North America, AMP drawings can be obtained via FAX using the free AMP FAX service. Call 1-800-522-6752 from a touchtone phone and order customer prints using the AMP part number. Additional information on the connectors is available in AMP application note number AMP 114-1060 and reliability information is available in AMP product specification 108-1297.

Figure 4.1 illustrates the mechanical footprint for the RTR-10 router and vertically mounted socket. Figure 4.2 shows the recommended PCB pad layout for the vertically mounted socket. Figures 4.3 and 4.4 provide the same information for the right-angle socket.

Decisions about component placement on the motherboard must consider electromagnetic interference (EMI) and electrostatic discharge (ESD) issues discussed in Chapter 6 of this document.

RTR-10 PCB footprint when using AMP part number 8822021-1 (component side, vertical mounting)

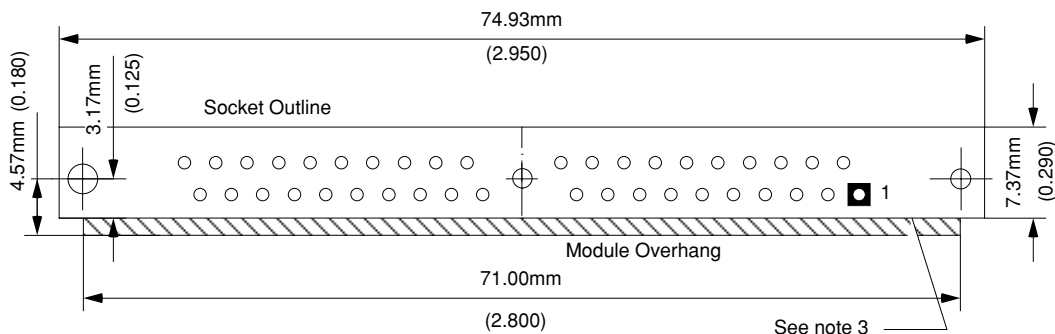

Notes:

1. Dimensions in mm (inches)
2. Tolerances $\pm .13\text{mm}$ (0.005)
3. Components standing higher than 3.81mm (.15) should not be closer than 12.4mm (0.5) to this edge of the socket to allow clearance to insert the module.
4. Allow 33.02mm (1.3) clearance above PCB over the foot print area. Additional clearance required to insert the module.
5. Socket dimensions are subject to change. Contact AMP for the most current information.

Figure 4.1 RTR-10 Vertical Socket Mechanical Foot Print

**Recommended PCB hole pattern (component side view)
for AMP part number 822021-1 (vertical mounting)**

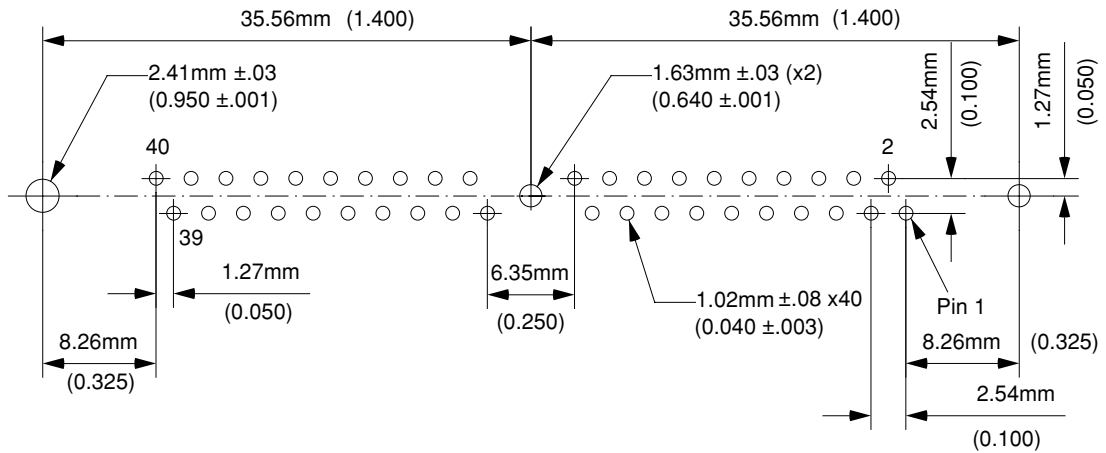

- Notes:
1. Dimensions in mm (inches)
 2. Tolerances $\pm .13\text{mm}$ (0.005)
 3. All socket dimensions are subject to change. Contact AMP for the most current information.

Figure 4.2 RTR-10 Vertical Socket Pad Layout

**RTR-10 PCB footprint when using AMP part number 4-382483-0
(component side, horizontal mounting)**

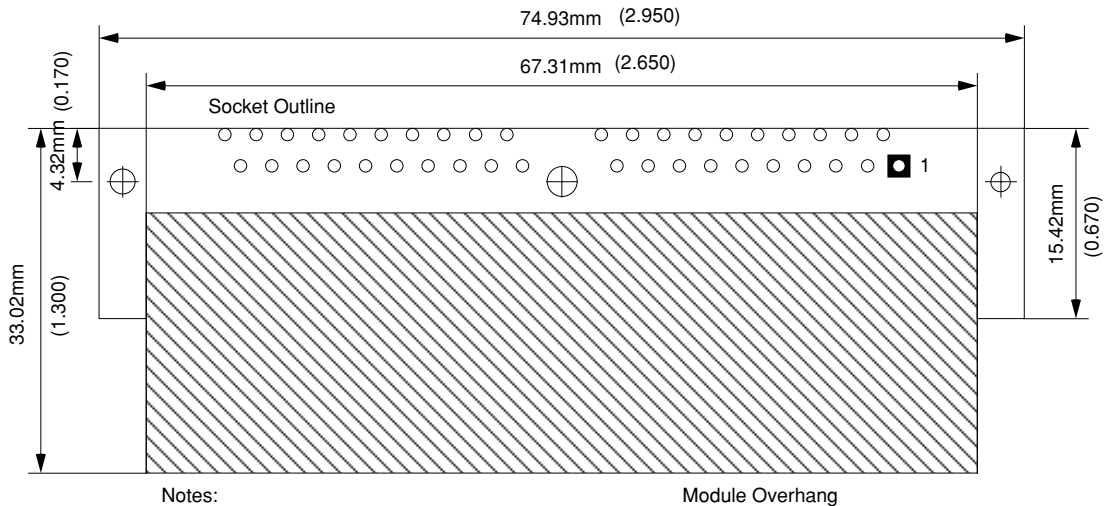

- Notes:
1. Dimensions in mm (inches)
 2. Tolerances $\pm .13\text{mm}$ (0.005)
 3. Do not position components in the overhang region.
 4. Allow 12.7mm (0.5) clearance above PCB over the entire footprint area. Additional clearance required during assembly to insert the module.
 5. Socket dimensions are subject to change. Contact AMP for the most current information.

Figure 4.3 RTR-10 Right-Angle Socket Mechanical Footprint

**Recommended PCB hole pattern (component side view)
for AMP part number 4-382483-0 (horizontal mounting)**

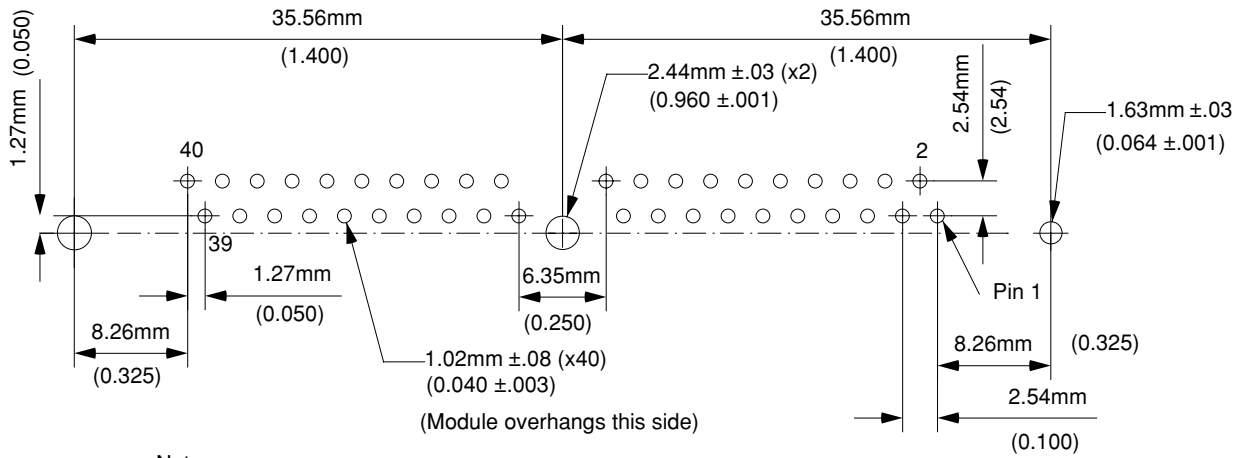

- Notes:
1. Dimensions in mm (inches)
 2. Tolerances $\pm .13\text{mm}$ (0.005)
 3. Socket dimensions are subject to change. Contact AMP for the most current information.

Figure 4.4 RTR-10 Right-Angle Socket Pad Layout

RTR-10 Power Requirements

The RTR-10 router requires a +5VDC $\pm 10\%$ power source with 200mA current.

Power Supply Decoupling and Filtering

The design for the RTR-10 power supply must consider filtering and decoupling requirements of the RTR-10 router. The power supply filter must prevent noise generated by the RTR-10 router from conducting onto external wires, and in the case of DC-DC switching power supplies, must prevent noise generated by the supply from interfering with module operation. Switching power supply designs must also consider the effects of radiated EMI.

The RTR-10 router requires a clean power supply to prevent RF noise from conducting onto the network through active drive circuits. Power supply noise near the network transmission frequency may degrade network performance.

The RTR-10 router includes 2.2 μ F and 0.1 μ F power supply bypass capacitors close to pins 10 and 31. In general, high-frequency decoupling capacitors valued at 0.1 μ F or 0.01 μ F placed near pins 10 and 31 on the motherboard are necessary to reduce EMI.

Low Voltage Protection

It is necessary to include a low voltage protection circuit on the router motherboard to drive the \sim RESET line of the RTR-10 router. See Section 9.4 of the *Neuron Chip Data Book*. Failure to include such protection may cause data corruption to configuration data maintained in EEPROM on the RTR-10 Neuron Chips. In the sample circuit of figure 5.1, protection is provided via a Motorola MC33164.

Electrical Interface

The pinout of the RTR-10 Router Core Module is shown in table 4.1. See Chapter 6 of the *Neuron Chip Data Book* for more information about the use of the Neuron Chip communication port pins. For the transceiver interface in the sample schematic of figure 5.1, ESD protection diodes are used on the CP0 and CP1 comm lines, and the center tap of the twisted pair coupling transformer is bypassed to ground.

Table 4.1 Pinout of the RTR-10 router

Name	Function	Pin #
ACLK2	A-side output clock	27
ACP0	A-side network communication port 0	8
ACP1	A-side network communication port 1	7
ACP2	A-side network communication port 2	6
ACP3	A-side network communication port 3	9
ACP4	A-side network communication port 4	5
~ASVC	A-side service output	12
AXID0	A-side transceiver ID 0 (LSB)	20
AXID1	A-side transceiver ID 1	18
AXID2	A-side transceiver ID 2	17
AXID3	A-side transceiver ID 3	16
AXID4	A-side transceiver ID 4 (MSB)	15
BCLK1	B-side input clock	29
BCLK2	B-side output clock	33
BCP0	B-side network communication port 0	37
BCP1	B-side network communication port 1	38
BCP2	B-side network communication port 2	39
BCP3	B-side network communication port 3	36
BCP4	B-side network communication port 4	40
BXID0	B-side transceiver ID 0 (LSB)	22
BXID1	B-side transceiver ID 1	24
BXID2	B-side transceiver ID 2	23
BXID3	B-side transceiver ID 3	21
BXID4	B-side transceiver ID 4 (MSB)	19
~BSVC	B-side service output	28
GND	Ground	1, 2, 3, 11, 26, 30, 32, 34
PKT	Packet forward output	14
~RESET	Reset input and output	25
~SERVICE	Combined service input	13
VCC	+5VDC input	10, 31
NC	No connect	4, 35

ACLK2, BCLK1, and BCLK2

A 10-MHz crystal is provided for Side A of the RTR-10 router, which can only run at 10 MHz. This clock rate allows Side A to be used with transceivers running at interface bit rates from 9.8kbps to 1.25Mbps. The 10-MHz clock is output on the ACLK2 pin, allowing Side B to be tied directly to the same clock through pin BCLK1. Thus, no external components are required to support the same range of bit rates on Side B. The 10-MHz output can be divided to a lower frequency with external hardware and used as the input clock for Side B to support transceivers running at interface bit rates as low as 610bps. ACLK2 can drive 5 LS-TTL loads.

ACP(4..0) and BCP(4..0)

The ACP[4..0] and BCP[4..0] signals are connected to the CP[4..0] pins of the core module Neuron Chips. The function of these pins is described in Chapter 6 of the *Neuron Chip Data Book*.

~ASVC and ~BSVC

Each side of the RTR-10 router has an independent service output : ~ASVC for the A Side and ~BSVC for the B Side. These outputs may be attached to service LEDs as shown in figure 5.1. The function of the service pin is described in Chapter 9 of *Neuron Chip Data Book*. The internal pullup resistor for the service pin on each side is enabled. The service LEDs reflect the firmware status: *blinking* means that the router side is unconfigured, *off* means that the side is configured, and *on* means that the side has failed.

AXID (4..0) and BXID (4..0)

The RTR-10 router comes preconfigured with many common LONWORKS transceiver parameters. Two sets of five transceiver identification (ID) pins on the RTR-10 router select the appropriate transceiver type for each side. The transceiver ID inputs eliminate a manufacturing step by automatically configuring the RTR-10 router for most transceivers. A special transceiver ID is reserved for programming any custom transceiver type. This value causes the communication port pins to be configured as all inputs so that no line will be driven by both the transceiver and RTR-10 Neuron before the RTR-10 Neuron Chips can be properly configured.

The RTR-10 firmware reads the transceiver ID inputs on power up and reset. If the router is being powered-up for the first time, or if the transceiver ID is different from the last time it was powered-up, the parameters specified in table 4.2 are loaded. If the router is being re-powered-up, and the transceiver ID is not 30, the RTR-10 firmware compares the network bit rate and input clock for the specified transceiver to the current transceiver parameters. If these parameters don't match, than all transceiver parameters are reinitialized. This allows a network services tool to change parameters, such as the number of priority slots, without the new values being overwritten by the RTR-10 firmware.

Table 4.2 RTR-10 Router Transceiver IDs

<i>ID</i>	<i>Name</i>	<i>Media</i>	<i>Bit Rate (bps)</i>	<i>Input Clock</i>
01 (01 hex)	TP/XF-78	Transformer-Isolated Twisted Pair	78k	10MHz
03 (03 hex)	TP/XF-1250	Transformer-Isolated Twisted Pair	1.25M	10MHz
04 (04 hex)	TP/FT-10	Free Topology and Link Power	78k	10MHz
05 (05 hex)	TP/RS485-39	RS-485 Twisted Pair	39k	10MHz
07 (07 hex) ¹	RF-10	49MHz Radio Frequency	4.9k	5MHz
09 (09 hex)	PL-10	Spread-Spectrum Power Line	10k	10MHz
10 (0A hex)	TP/RS485-625	RS-485 Twisted Pair	625k	10MHz
11 (0B hex)	TP/RS485-125	RS-485 Twisted Pair	1.25M	10MHz
12 (0C hex)	TP/RS485-78	RS-485 Twisted Pair	78k	10MHz
16 (10 hex) ²	PL-20C	C-Band Power Line	5kbps	10MHz
17 (11 hex) ²	PL-20N	C-Band Power Line	5kbps	10MHz
18 (12 hex)	PL-30	A-Band Power Line	2kbps	10MHz
24 (18 hex)	FO-10	Microsym Fiber Optic	1.25M	10MHz
27 (1B hex)	DC-78	Direct Connect	78k	10MHz
28 (1C hex)	DC-625	Direct Connect	625k	10MHz
29 (1D hex)	DC-1250	Direct Connect	1.25M	10MHz
30 (1E hex) ³	Custom	Custom	N/A	N/A

Note: See Appendix A for a listing of the communications parameters for each transceiver type.

- 1 Type 7 can only be used on Side B.
- 2 PL-20C enables the CENELEC-compliant access protocol; PL-20N disables it.
- 3 Type 30 can be used for any transceiver type; the communications port is initially defined as all inputs to prevent circuit conflicts. The side using type 30 must be reprogrammed via the other router side.

PKT

The PKT output can be used as an activity indicator. When packets are passed between the router sides, PKT will be active. This is the unbuffered IO0 signal from the Neuron Chips. A pulse stretcher circuit driven by PKT can be used to make an activity LED flash, as in the example circuit shown in figure 5.1.

~RESET

The Neuron Chip reset pins are tied together and brought out on one pin. Figure 4.5 shows the reset circuitry on the RTR-10 router. Typical applications do not require debounce conditioning of a momentary push button attached to the ~RESET pin. The software response time associated with this input is long enough to effectively provide a software debounce for switches with a contact bounce settling time as long as 20 milliseconds. The ~RESET signal must be driven low by a low voltage protection circuit on the router motherboard as described under *Low Voltage Protection* earlier in this chapter.

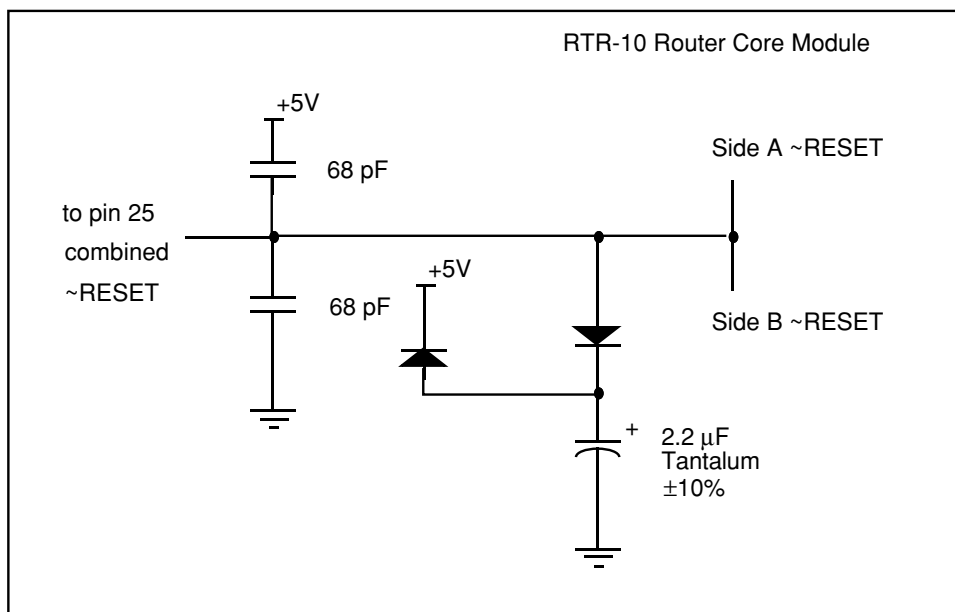

Figure 4.5 RTR-10 Reset Circuit

~SERVICE

The ~SERVICE input drives both sides of the RTR-10 router from a single input. A push-button connected to this pin may be used during installation to broadcast each side's 48-bit Neuron ID on its channel. Typical applications do not require debounce conditioning of a momentary push button attached to the ~SERVICE pin. The software response time associated with this input is long enough to effectively provide a software debounce for switches with a contact bounce settling time as long as 20 milliseconds.

5

Developing a Router with the RTR-10 Module

This chapter describes the process of developing a router based on the RTR-10 Router Core Module. If you are using the Model 71000 LONWORKS Router, skip this chapter.

Overview

To create a router, follow these steps:

- 1** Build a router motherboard according to the specifications described in Chapter 4 and the guidelines described in Chapter 6. The motherboard may be part of custom application hardware, or may be a standalone board. Figure 5.1 is a sample motherboard schematic for a TP/XF-78 to TP/XF-1250 twisted pair router. Additional transceiver interfaces are described in the next section.
- 2** Ensure that the communications parameters in the RTR-10 router are compatible with both of the transceivers. The transceivers listed in table 4.2 are supported directly by the RTR-10 router as predefined types. Set the transceiver ID lines to select the proper transceiver type. For custom transceivers, modify the communications parameters as described under *Using Custom Transceivers* in this chapter.
- 3** Assemble the router, including the RTR-10 router, 2 transceivers, and a motherboard.
- 4** Install the router on a network as described in Chapter 7. The network may be a development network for initial testing, a manufacturing network for configuration during manufacture, or a production network for field installation.

Using Predefined Transceivers

The RTR-10 router includes built-in transceiver parameters for the transceivers listed in table 4.2. When using any of these transceivers, the communications parameters are automatically programmed as described in Chapter 4.

The user's guide for each transceiver contains documentation on the interface requirements. You also must set the transceiver ID input for each side of the RTR-10 as shown in table 4.2.

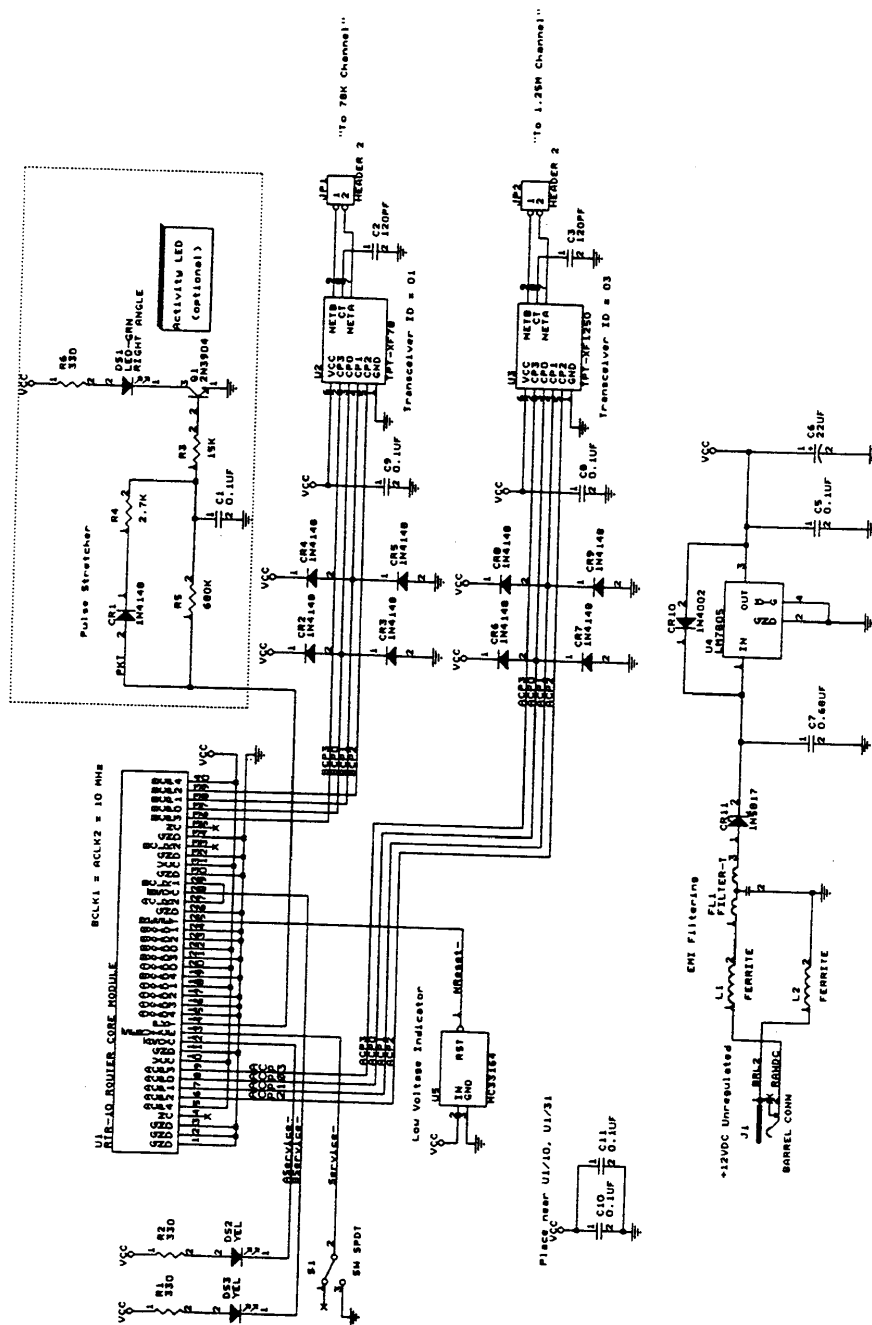

Figure 5.1 Router Motherboard Sample Schematic

Using Custom Transceivers

The RTR-10 router can be used with transceivers not listed in table 4.2 as long as the communications parameters are reprogrammed to match the custom transceiver. If one side of the router is a predefined transceiver type, this reprogramming can occur during manufacture or during field installation. The first four steps of the following procedure describe how the custom communications parameters are programmed for one side. If both sides of the custom router will be custom transceiver types, additional configuration steps will be required as described in steps 5 - 10.

- 1 Assuming that the predefined transceiver is on Side A, attach a transceiver matching one of the predefined types to Side A of the RTR-10 and select the matching transceiver ID on Side A.
- 2 Select the custom transceiver type (ID 30) on Side B of the RTR-10 router.
- 3 Attach a network services tool, such as LonMaker, with a compatible predefined transceiver to Channel A as shown in figure 5.2.

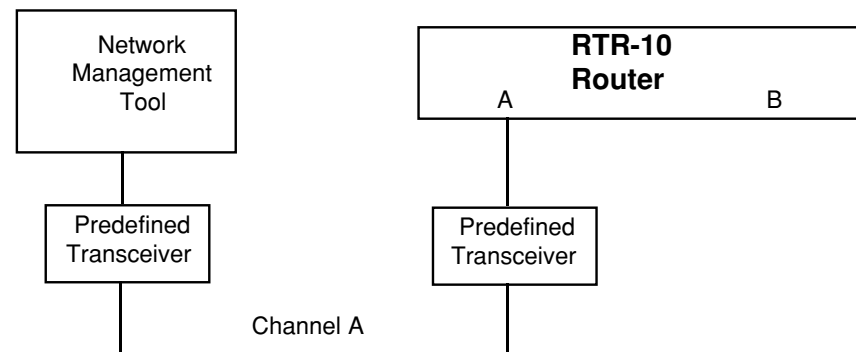

Figure 5.2 Configuring Side B

- 4 Configure the communications parameters on Side B of the RTR-10 router using the network management tool. Side A may be automatically reconfigured at the same time depending on the network management tool.

Installation procedures for LonMaker, LonBuilder, and the LonManager API are described in Chapter 7.

The preceding 4 steps complete the configuration when a single custom transceiver is used. Proceed with the following 6 steps if two custom transceivers are to be used with the RTR-10 router.

- 5 Remove power from the RTR-10 router.
- 6 Disconnect the predefined transceiver from Side A.
- 7 Select the custom transceiver ID (type 30) on Side A.
- 8 Attach the selected custom transceiver to Side B as shown in figure 5.3, leaving the Side B transceiver ID set to 30.
- 9 Attach a network services tool with a compatible custom transceiver to Channel B as shown in figure 5.3.

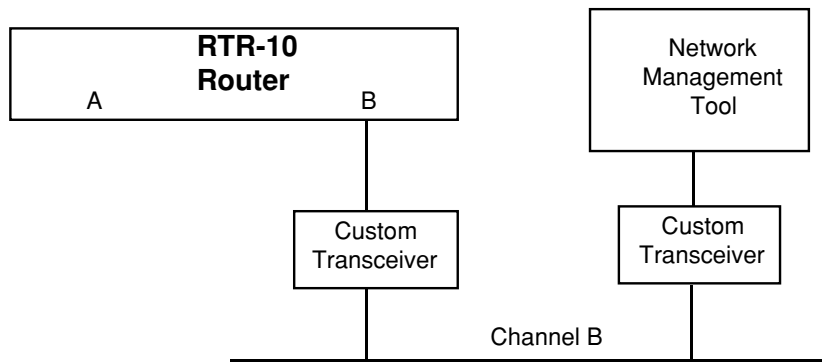

Figure 5.3 Configuring Side A

- 10 Configure the communications parameters on side A of the RTR-10 router using the network management tool. Side B may be automatically reconfigured at the same time depending on the network services tool.

6

RTR-10 Design Issues

This chapter examines a number of design issues, including a discussion of electromagnetic interference (EMI) and electrostatic discharge (ESD). If you are using the Model 71000 LONWORKS Router, skip this chapter.

EMI Design Issues

The high-speed digital signals associated with microcontroller designs can generate unintentional Electromagnetic Interference (EMI). High-speed voltage changes generate RF currents that can cause radiation from a product with a length of wire or piece of metal that can serve as an antenna.

Products that use the RTR-10 router will generally need to demonstrate compliance with EMI limits enforced by various regulatory agencies. In the USA, the FCC requires that unintentional radiators comply with Part 15 level "A" for industrial products, and level "B" for products that can be used in residential environments. Similar regulations are imposed in most countries throughout the world. For more information about regulations, see *VDE 0871*, Class "B" 1984, and *CISPR Publications 22*, proposed new European EMC Standard.

Echelon has designed the RTR-10 router with low enough RF noise levels for design into level "B" products. Echelon encourages level "B" compliance for all LONWORKS-compatible products. This section describes design considerations for RTR-10 router-based products to meet EMI regulations.

Designing Systems for EMC (Electromagnetic Compatibility)

The RTR-10 router has been designed so that products using it should be able to meet both FCC and VDE level "B" limits. Careful system design is important to guarantee that an RTR-10 router-based product will achieve the desired EMC. Information on designing products for EMC is available in several forms including books, seminars, and consulting services. This section provides useful design tips for EMC.

EMC Design Tips

- Most of the RF noise originates in the CPU portion of the RTR-10 router--which effectively means the entire board.
- Most of the EMI will be radiated by the network cable and the power cable.
- Filtering is generally necessary to keep RF noise from getting out on the power cable.
- EMI radiators should be kept away from the RTR-10 router to prevent internal RF noise from coupling onto the radiators.
- The RTR-10 router must be well grounded to ensure that its built-in EMI filtering works properly.

- Early EMI testing of prototypes at a certified outdoor range is an extremely important step in the design of level “B” products. This testing ensures that grounding and enclosure design questions are addressed early enough to avoid most last-minute changes.

ESD Design Issues

Electrostatic Discharge (ESD) is encountered frequently in industrial and commercial use of electronic systems. Reliable system designs must consider the effects of ESD and take steps to protect sensitive components. Static discharges occur frequently in low-humidity environments when operators touch electronic equipment. The static voltages generated by humans can easily exceed 10kV. Keyboards, connectors, and enclosures provide paths for static discharges to reach ESD sensitive components such as the Neuron Chip. This section describes techniques to design ESD immunity into RTR-10 router-based products.

Designing Systems for ESD Immunity

ESD hardening includes the following techniques:

- Provide adequate creepage and clearance distances to prevent ESD hits from reaching sensitive circuitry;
- Provide low impedance paths for ESD hits to ground;
- Use diode clamps or transient voltage suppression devices for accessible, sensitive circuits

The best protection from ESD damage is circuit inaccessibility. If all circuit components are positioned away from package seams, the static discharges can be prevented from reaching ESD sensitive components. There are two measures of "distance" to consider for inaccessibility: creepage and clearance. *Creepage* is the shortest distance between two points along the contours of a surface. *Clearance* is the shortest distance between two points through the air. An ESD hit generally arcs farther along a surface than it will when passing straight through the air. For example, a 20kV discharge will arc about 0.4 inches (10 mm) through dry air, but the same discharge can travel over 0.8 inches (20mm) along a clean surface. Dirty surfaces can allow arcing over even longer creepage distances.

When ESD hits to circuitry cannot be avoided through creepage, clearance and ground guarding techniques, i.e., at external connector pins, explicit clamping of the exposed lines is required to shunt the ESD current. Consult *Protection of Electronic Circuits from Overvoltages*, by Ronald B. Standler, for advice about ESD and transient protection for exposed circuit lines. In general, exposed lines require diode clamps to the power supply rails or zener clamps to chassis ground in order to shunt the ESD current to ground while clamping the voltage low enough to prevent circuit damage. The Neuron Chip's communications port lines are connected directly to the RTR-10 edge connector without any ESD protection beyond that provided by the chip itself. If these lines will be exposed to ESD in a custom router, protection must be added to the router motherboard.

7

Installing a Router

This chapter describes how to install LONWORKS routers.

Introduction

To install a router, follow these steps:

- 1 Define a network topology.
- 2 Physically attach the router to a LONWORKS network.
- 3 Connect power to the router.
- 4 Logically install the router on the network.
- 5 Test the router installation.

These steps are described in more detail in the following sections.

Defining a Network Topology

There are many possible network topologies when using routers. The first rule for initial integration is that if a network services tool is used for installation, then a physical or logical path must exist between the network services tool and the router targeted for installation. A physical path is created if the network services tool is connected to the same media as one side of the LONWORKS Router. A logical path is created if one or more active installed routers exist between the LONWORKS Router and the network services tool. The routers creating the logical path may be LONWORKS Routers, LonBuilder Routers, or custom routers based on the RTR-10 Router Core Module. The routers in the logical path must be installed, loaded, and online before the new router may be added to the network.

When installing routers on a development network, the LonBuilder or LonManager Protocol Analyzer can be used to verify that a path exists to a router to be installed. To verify the existence of a logical path, press the service switch of a powered router. If a physical or logical path to the protocol analyzer exists, this action will increment the packets received count. A detailed view of the packet log resulting from the previous action will show a code of 0x7F; this is the message code for an unsolicited service pin message.

Attaching the Router to a Network

The next step in installation is to physically attach the router to two channels in a LONWORKS network. It is important to insure that each channel has only one transceiver type attached to it. Mixing signals from different transceivers will defeat the collision avoidance algorithms and therefore severely degrade network performance.

Custom routers based on the RTR-10 Router Core Module are attached to a network as described in the router developer's documentation. The remainder of this section describes how to attach the Model 71000 LONWORKS Router.

The wire used for the network will affect the overall system performance with respect to distance, stub length, and total number of nodes supported on a single channel. See the *LONWORKS FTT-10 Free Topology Transceiver User's Guide* for wiring guidelines for free topology channels; see the *LONWORKS LPT-10 Link Power Transceiver User's Guide* for wiring guidelines for link power channels. For TP/XF and TP/RS485 channels, Echelon recommends the use of UL Level IV, 22 AWG twisted-pair cable for the network bus as defined in *UL's LAN Cable Certification Program*, UL document number 200-120 20 M/11/91.

The router can be connected to the bus using a 24 AWG stub with an RJ-45 connector on one end and flying leads on the other. For free topology and link power channels, the 24 AWG stubs must be limited to 0.3m (1 foot), with no more than five 24 AWG stubs per segment. Longer stubs can be used by splicing the 24 AWG stub to the heavier gauge wire specified in the free topology and link power user's guides. See the *Junction Box and Wiring Guidelines for Twisted Pair LONWORKS Networks* engineering bulletin (part number 005-0023-01) for information on connecting to a twisted pair channel.

The pin-out for the RJ-45 connector is shown in figure 7.1. The connector is viewed from the outside, looking in, with the contacts at the top, pin 1 is at the left. The pins are numbered sequentially, left to right.

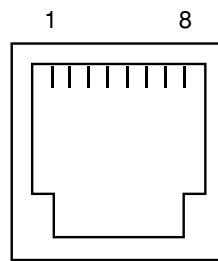

Pins 1 and 2	Network connections
Pins 3 through 6	No connect
Pin 7	Connected to the signal ground via a 100 ohm resistor (used for TP/RS485 only)
Pin 8	Reserved

Figure 7.1 RJ-45 Connector

The connection between pin 7 and local signal ground provides a means for reducing common-mode voltages between nodes on a TP/RS485 channel. In the typical case, pin 7 would be connected to either earth ground or to a separate network ground. A network ground can be provided by a third conductor or cable shield in the twisted pair cable. Two 100 ohm resistors within the router are used to limit circulating current when a network ground is used. For safety, the 100 ohm resistors are actually thermistors which changes to high impedance if overloaded. See the *EIA RS-485 Standard*, Electronic Industries Association, April 1983. This document is available through Global Engineering Documents in Irvine, California at +1 (714) 261-1455 or (800) 854-7179.

Proper electrical termination is essential for each twisted pair channel. Failure to terminate the network will degrade performance and in some cases eliminate a node's ability to communicate to other nodes. For TP/XF and TP/RS485 channels, the terminator circuits shown in figure 7.2 should be used. The terminators provided with the LonBuilder and NodeBuilder™ TP/XF kits also may be used. See the *LONWORKS FTT-10 Free Topology Transceiver User's Guide* for information on terminating a free topology network; see the *LONWORKS LPT-10 Link Power Transceiver User's Guide* for information on terminating a link power network.

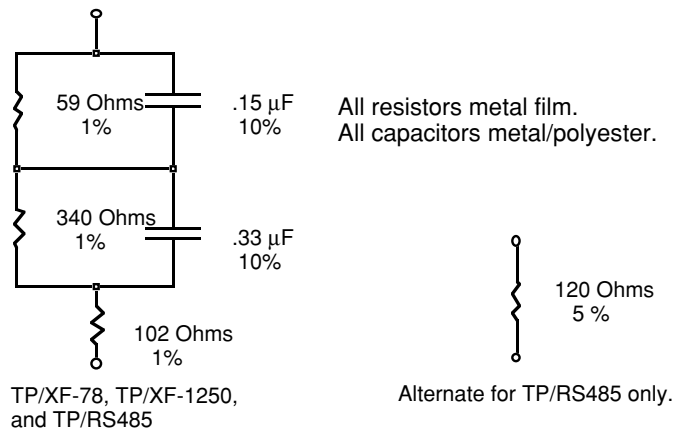

Figure 7.2 Network Termination Circuits for TP/XF and TP/RS485 Networks

Connecting Power

Once the router is physically attached to the desired channels, power must be supplied. Power is supplied to the Model 71000 LONWORKS Router via the power input connector on the side of the router. The router may be ordered with a wall-mount power supply, or you can create your own. Four power supply options are available for the router, depending on the country for which the router is intended. These are USA/Canada, United Kingdom, Continental Europe, and Japan. The output voltage is a nominal +9VDC at 500mA. The following table describes the basic characteristics of the four power supply types.

Table 7.1 Power Supply Characteristics

Country or Region	Nominal Input Voltage	Input range nominal ±10%	Frequency	Input connector	Echelon Model #
USA/Canada	120 VAC	108-132 VAC	60 Hz	2-prong, NEMA 1-15P	78010
Japan	100 VAC	90 - 110 VAC	50/60 Hz	2-prong, NEMA 1-15P	78040
U.K.	240 VAC	216 - 264 VAC	50 Hz	3-prong, U.K. Plug	78030
Europe	220 VAC	198 - 242 VAC	50 Hz	2-prong, Euro Plug	78020

Any power supply may be used for the Model 71000 LONWORKS Router that meets the following specifications: the power input to the router must be +9 to 15VDC at 500mA, negative tip, outer barrel positive. The connector is a standard female DC power plug with a 2.1mm inside diameter and 5.5mm outside diameter. LZR Electronics part number HP-114A, or Radio Shack catalog number 274-1569 will comply.

When power is connected to a router, the Status and Service LEDs will change state as described in figures 7.3 and 7.4. Once a router is powered and configured, the Service LEDs will stay off unless the service request button is pressed.

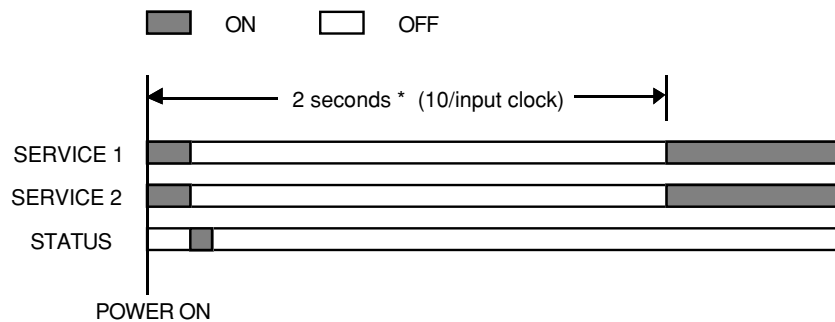

Figure 7.3 LED Display Timing for Unconfigured Routers

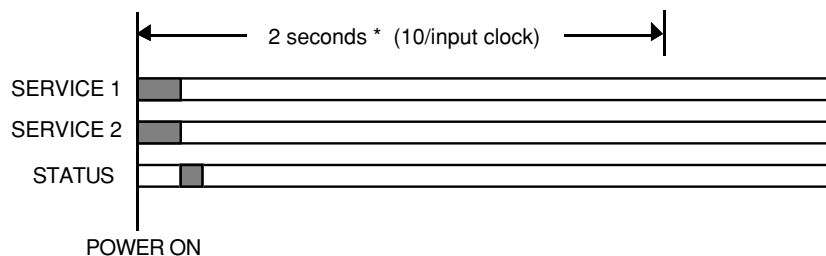

Figure 7.4 LED Display Timing for Configured Routers

Installing the Router on a Network

Once a router is physically attached to a network, and powered-up, it must be logically installed on the network. A router may be installed using a network services tool such as the LonMaker Installation Tool or the LonBuilder Network Manager, or a custom network services tool based on the LonManager API. Alternatively, a custom network services tool can be implemented using the router network management messages defined in Chapter 8, but this is recommended only for very simple networks with no more than a few routers due to the complexity of calculating timing parameters and forwarding tables for complex networks.

Router Installation with Network Management Messages

Routers can be installed using the network management messages described in Chapter 8 and in Appendix B of the *Neuron Chip Data Book*, but this process is only recommended for simple networks with few routers. The process is similar to application node installation as described in the *LONWORKS Installation Overview* engineering bulletin (number 005-0006-01). To install a router with network management messages, follow these steps:

- 1 Change the router state to *Unconfigured* with the *Set Node Mode* network management message.
- 2 Assign one or two domains, subnets, and node IDs to both sides of the router with the *Update Domain* network management message. When installing the router in one domain, the same domain must be assigned to both sides. When installing the router in two domains, the same domain must be assigned as the first domain on both sides, and the same domain must be assigned as the second domain on both sides.
- 3 Select a routing algorithm for both sides of the router with the *Write Memory* network management message as described in Chapter 8. Both sides must be set to the same algorithm.
- 4 For configured routers, load the group and subnet routing tables on both sides of the router with the *Group or Subnet Table Download* network management message. There are 255 forwarding flags for subnets and 255 forwarding flags for groups on each side for each domain.
- 5 Initialize the routing tables using the *Set Router Mode* network management message.
- 6 Change the router state on both sides of the router to *Configured, on-line* with the *Set Node Mode* network management message.

Router Installation with the LonMaker Installation Tool

LonMaker is an end-user tool that supports installation of routers and application devices. See Chapters 4 and 5 of the *LonManager LonMaker User's Guide* for a description of router installation. The channel types should be defined using the LonManager Profiler based on the communications parameters listed in Appendix C.

Router Installation with the LonManager API

The LonManager API includes functions that simplify the process of installing routers, and also automatically adjust application node timing parameters based on network topology. For DOS applications, see Chapter 9, *Managing Channels and Routers*, of the *LonManager API Programmer's Guide*. Also see Chapter 10, *Installing and Managing Routers* in the same manual. For Windows applications, see Chapter 10, *Installing and Managing Routers* in the *LonManager API Programmer's Guide for Windows*.

Router Installation with the LonBuilder Developer's Workbench

Chapter 9 of the *LonBuilder User's Guide* describes how to define and install routers in a development network using the LonBuilder Network Manager. A prerequisite to creating router target hardware and node specifications is the definition of the channels that will be included in the network as defined under *Defining Channels* in Chapter 10 of the *LonBuilder User's Guide*. Routers are initially delivered programmed with communications parameters listed in Appendix C. These values should be used in the `Std Xcvr Type` field when defining channels with the possible changes discussed next. Be sure to correctly set the minimum clock rate field. If this field is set incorrectly, excessive collisions will occur. If a channel includes nodes with a slower clock rate or less accurate clocks, the channel definition must meet this lowest common denominator for optimal performance.

Additionally, if priority is configured for either channel, then the `Number of Priority Slots` needs to be correctly set. If the `Average Packet Size` expected on either channel is different than the standard transceiver type, optimal operation of the collision avoidance algorithm requires that value to be changed also.

When defining the target hardware for the router specify `LONWORKS Router` for the `Router HW Type` field. The assignment of sides A and B to channel names is arbitrary, and does not have to correspond to the Net 1 and Net 2 assignments on the router. The LonBuilder Network Manager and the LonManager API will assign the correct associations when the router is installed.

Set the `Packet Buffer` count and size fields to the count and size of the non-priority output buffer queue as described under *Message Buffers* in Chapter 2.

Set the `Clock Rate` field to one of the following:

- 10MHz for side A of the RTR-10, and for LONWORKS Router sides with TP/XF-1250 transceivers;
- 5MHz for LONWORKS Router sides with TP/FT-10, TP/XF-78, or TP/RS485 transceivers;
- Match the B-side input clock for side B of the RTR-10. This will typically be 10MHz.

When installing the router, the channel definitions must match the transceivers on the router, if they do not, the router could lose its ability to communicate. If either of the channel definitions are modified from the standard transceiver types, then a `Yes` response is required to the prompt, `Do you want to install communications parameters?` in order for those changes to be programmed in the router; otherwise specify `No`.

WARNING: DO NOT use the Yes response to the prompt: Do you want to install communications parameters? unless you have defined channels that are compatible with the transceivers on the router.

When defining subnets for the router node specification, remember that a subnet may not span two channels that are connected by intelligent routers. For a LONWORKS network containing two channels connected with an intelligent router, a minimum of two subnets must be created, one for each channel. Each side of the router must belong to at least one

subnet. For managing the assignment of subnets to application nodes, it is helpful to define subnets with meaningful names that correspond to the channels to which they are assigned. Bridges and repeaters may have both sides of the router on the same subnet.

Configured and learning routers are loaded over the network to program the routing tables, and the subnet/node assignment. An Automatic Load will insure that the router receives the latest configuration information for subnet and group routing.

Once a router is installed, configured, and loaded, its function in the network becomes transparent if you allow the network services tool to automatically configure the transport layer timing parameters of the other nodes in the network. These parameters are described under *Setting Parameters for Connections* in Chapter 11 of the *LonBuilder User's Guide*. This is the default for each network variable and message tag connection created. The automatic configuration of these parameters will account for the router hop delays and adjust accordingly. If a node responds to a network variable that is several router hops away, but the packet log indicates that retries by the sending node are frequently occurring, the transport layer timing parameters have probably been manually set to values that are too low.

Testing Router Installation

Once a router has been installed, the *Query Status* network diagnostic message can be used to ensure that it is operational. If no response is received, all intermediate routers should be queried to determine where the fault occurred. If the router has been installed with LonMaker, the Test command described under *Testing Devices* in Chapter 6 of the *LonMaker Installation Tool User's Guide* can be used to query router status. If the router has been installed on a development network with the LonBuilder Network Manager, the Test command described under *Testing Routers* in Chapter 13 of the *LonBuilder User's Guide* can be used to query router status. See the description of the *Query Status* message in Chapter 8 for a description of the error codes returned by the *Query Status* message.

Building a Router Mounting Bracket

The Model 71000 LON WORKS Router may be wall-mounted using a custom mounting bracket. The following figure is a mechanical drawing of a suitable bracket that can be constructed by any sheet-metal subcontractor. All measurements are in inches.

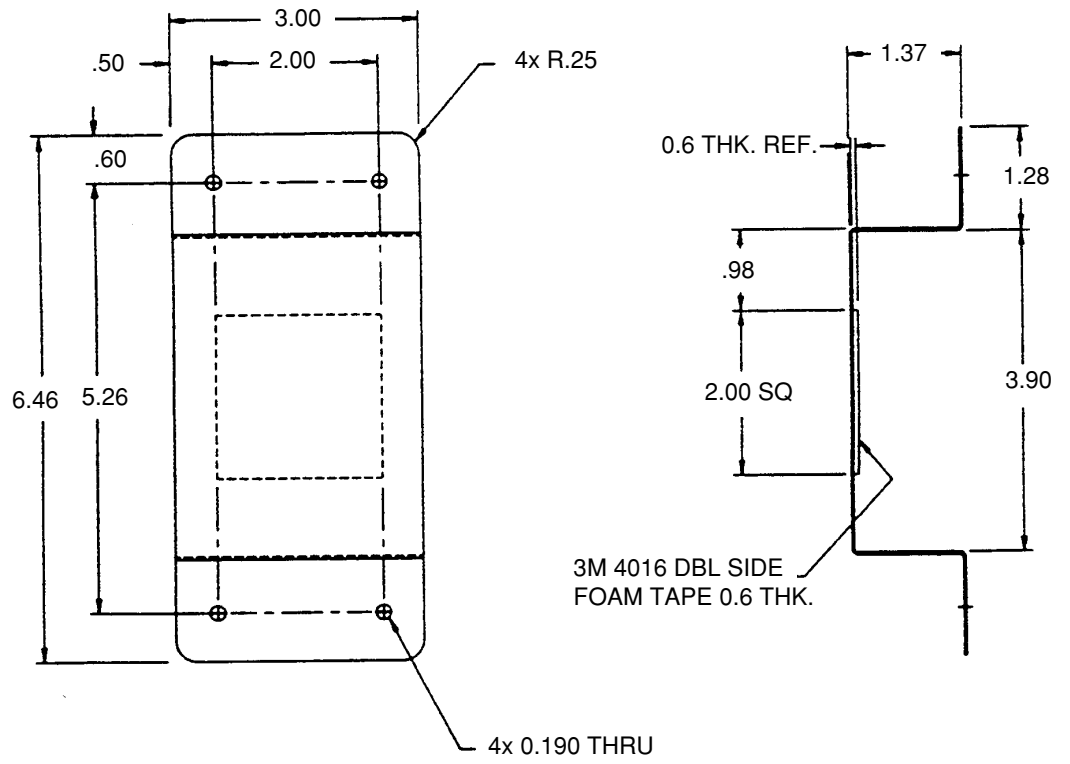

Figure 7.5 Router Mounting Bracket

8

Network Management Messages

This chapter describes network management services for LONWORKS Routers. These services are used for router installation as described in Chapter 7.

Introduction

As described in the previous chapter, routers are installed using network management messages. These messages are sent as explicit messages by a network services tool. Routers respond to many of the same messages as any LONWORKS application node, and also have an additional set of router specific messages.

Several router options are set using the *Write Memory* network management message. These options are specification of routing algorithm, buffer sizes, and non-priority output buffer queue count.

Standard Messages

Routers accept the standard network diagnostic and network management messages listed in tables 5.1 and 5.2. These messages are described in Appendix B of the *Neuron Chip Data Book*.

The following exceptions apply to standard network management messages when used with routers:

- The *Query Status* network diagnostic message reports two errors that are unique to the router. These errors are listed in Appendix B of the *Neuron data book*, but are not described in Chapter 11 of the *Neuron C Reference Guide*. The two errors are:
 - **Subnet inconsistency (159 decimal, 9F hex)**. A message was received by a learning router with a source subnet that was inconsistent with the current subnet forwarding table. To prevent loops, the inconsistent subnet is set to no forwarding on both sides of the router. A network services tool can use this error to detect nodes that have been moved between channels. A learning router with this error logged should be reset by a network services tool to restart the learning process.
 - **Router firmware version mismatch (164 decimal, 0A4 hex)**. The router firmware version numbers on the two sides of a router do not match. In most cases, this error can be ignored, since router firmware normally does communicate correctly with router firmware of a different version number. The *Query Status* network diagnostic message may be used to determine the firmware version number. This message may be sent using the Test function of the LonBuilder, LonMaker, or NodeBuilder software.

Routers based on the RTR-10 Router Core Module always have matching firmware. Packaged routers are based on a pair of router modules. Router modules may have firmware version numbers of 4, 5, or 125. Router modules with version 4 firmware communicate correctly only with other router modules with version 4 firmware. Router modules with version 5 and version 125 firmware communicate correctly with each other. The following table summarizes the compatibility of router module firmware versions.

Firmware version	4	5	125
4	No error	<i>Version mismatch, incompatible</i>	<i>Version mismatch, incompatible</i>
5	<i>Version mismatch, incompatible</i>	No error	Version mismatch, but compatible
125	<i>Version mismatch, incompatible</i>	Version mismatch, but compatible	No error

- The *Set Node Mode* network management message is automatically processed by both sides of a router when it is used to place the router offline and online (the APPL_OFFLINE and APPL_ONLINE options).
- When the *Set Node Mode* message is used to place a router offline, the router will stop forwarding and all messages not addressed to the router will be dropped.
- The router will not respond to *Set Node Mode* messages that use a broadcast address. This prevents broadcast Restart or Offline messages from stopping the router and preventing the same broadcast message from reaching destinations on the other side of the router. Routers must therefore be restarted or taken offline using a *Set Node Mode* message addressed directly to the router.

Table 8.1 Network Diagnostic Messages

Network Diagnostic Messages	Request Code	Success Response	Failed Response
<i>Query Status</i>	0x51	0x31	0x11
<i>Proxy Command</i>	0x52	0x32	0x12
<i>Clear Status</i>	0x53	0x33	0x13
<i>Query XCVR Status</i>	0x54	0x34	0x14

Table 8.2 Network Management Messages

Network Management Messages	Request Code	Success Response	Failed Response
<i>Query ID</i>	0x61	0x21	0x01
<i>Respond to Query</i>	0x62	0x22	0x02
<i>Update Domain</i>	0x63	0x23	0x03
<i>Leave Domain</i>	0x64	0x24	0x04
<i>Update Key</i>	0x65	0x25	0x05
<i>Query Domain</i>	0x6A	0x2A	0x0A
<i>Set Node Mode</i>	0x6C	0x2C	0x0C
<i>Read Memory</i>	0x6D	0x2D	0x0D
<i>Write Memory</i>	0x6E	0x2E	0x0E
<i>Checksum Recalculate</i>	0x6F	0x2F	0x0F
<i>Memory Refresh</i>	0x71	0x31	0x11

Router Specific Messages

Router-specific network management messages are listed in table 8.3.

Table 8.3 Router-specific Network Management Messages

Network Management Messages	Request Code	Success Response	Failed Response
<i>Set Router Mode</i>	0x74	0x34	0x14
<i>Group or Subnet Table Clear</i>	0x75	0x35	0x15
<i>Group or Subnet Table Download</i>	0x76	0x36	0x16
<i>Group Forward</i>	0x77	0x37	0x17
<i>Subnet Forward</i>	0x78	0x38	0x18
<i>Group No Forward</i>	0x79	0x39	0x19
<i>Subnet No Forward</i>	0x7A	0x3A	0x1A
<i>Group or Subnet Table Report</i>	0x7B	0x3B	0x1B
<i>Router Status</i>	0x7C	0x3C	0x1C
<i>Far Side Escape Code</i>	0x7E	–	–

Router Specific Network Management Messages

Set Router Mode

This message instructs the router to perform one of several router-related tasks. The `NORMAL` option returns the router from the `TEMP_BRIDGE` mode. The `INIT_RTR_TABLE` option copies all forwarding tables from EEPROM into the RAM tables for a configured router, or, sets all RAM tables to flood for a learning router (this is the same action that occurs after node reset). The `TEMP_BRIDGE` option causes the router to temporarily forward ALL messages in the domain (until the next reset or *Set Router Mode* message with the `NORMAL` option). The *Set Router Mode* message affects **both** router sides. This message is conveyed via the Request-Response protocol.

Note that the standard *Set Node Mode* message may be used to take the entire router offline and online.

```
typedef enum {
    NORMAL          = 0,          // Not a temporary bridge.
    INIT_RTR_TABLE = 1,          // Copy forwarding tables from EEPROM
                                // for configured routers.
                                // Initialize forwarding tables for
                                // learning routers.
    TEMP_BRIDGE     = 2          // Temporarily a bridge until next reset
                                // or NORMAL router mode request.
} rtr_mode;
typedef rtr_mode NM_rtr_mode_request;
```

Group or Subnet Table Clear

This message is used to clear all entries in either the group or subnet forwarding table for a single domain for a *single router side*. The message is segmented to cover eight byte sections in order to prevent lengthy EEPROM write operations. This message is conveyed via the Request-Response protocol. The configuration checksum in EEPROM is updated.

```
typedef struct {
    unsigned group_or_subnet : 1; // 1 => Group, 0 => Subnet
    unsigned domain_index   : 1;
    unsigned unused         : 4;
    unsigned index_times_8  : 2;
} NM_rtr_table_clear_request;
```

Group or Subnet Table Download

This message is used to configure the entire group or subnet forwarding table in EEPROM for the specified domain for a single router side. The download function is broken into eight-byte sections. This message is conveyed via the Request-Response protocol. The configuration checksum in EEPROM is updated. Each byte in the table entry includes routing flags for eight subnets or groups.

The Least Significant Bit (LSB) of the table field maps to the lowest subnet or group ID in the current set of table entries defined by the `index_times_8` field. A value of '1' specifies that forwarding be enabled for the corresponding group or subnet; a value of '0' disables forwarding. Subnet 0 is used for special protocol functions and is never marked for forwarding.

```
typedef struct {
    unsigned    group_or_subnet : 1; // 1 => Group, 0 => Subnet
    unsigned    domain_index    : 1;
    unsigned    unused          : 4;
    unsigned    index_times_8   : 2;
    unsigned    table[8];      // Table data
} NM_rtr_table_downld_request;
```

Group Forward

This message sets the forwarding flag in the forwarding table for a given group in the specified domain. If the `ram_or_eeprom` field is set, both the RAM and EEPROM flags are set, otherwise only the RAM flag is set, allowing temporary forwarding for a given group. This message is conveyed via the Request-Response protocol. The configuration checksum in EEPROM is updated if EEPROM is changed.

```
typedef struct {
    unsigned    unused1        : 1;
    unsigned    domain_index    : 1;
    unsigned    unused2        : 5;
    unsigned    ram_or_eeprom   : 1; // 0 => RAM, 1 => RAM + EEPROM
    unsigned    group;
} NM_rtr_group_fwd_request;
```

Subnet Forward

This message sets the forwarding flag in the forwarding table for a given subnet in the specified domain. If the `ram_or_eeprom` field is set, both the RAM and EEPROM flags are set, otherwise only the RAM flag is set, allowing temporary forwarding for a given subnet. This message is conveyed via the Request-Response protocol. The configuration checksum in EEPROM is updated if EEPROM is changed.

```
typedef struct {
    unsigned    unused1        : 1;
    unsigned    domain_index    : 1;
    unsigned    unused2        : 5;
    unsigned    ram_or_eeprom   : 1; // 0 => RAM, 1 => RAM + EEPROM
    unsigned    subnet;
} NM_rtr_subnet_fwd_request;
```

Group No Forward

This message clears the forwarding flag in the forwarding table for a given group in the specified domain. If the `ram_or_eeprom` field is set, both the RAM and EEPROM flags are cleared, otherwise only the RAM flag is cleared, allowing temporary control of forwarding for a given group (see the *Router Status* message). This message is conveyed via the Request-Response protocol. The configuration checksum in EEPROM is updated if EEPROM is changed.

```
typedef struct {
    unsigned   unused1           : 1;
    unsigned   domain_index     : 1;
    unsigned   unused2           : 5;
    unsigned   ram_or_eeprom    : 1; // 0 => RAM, 1 => RAM + EEPROM
    unsigned   group;
} NM_rtr_group_nofwd_request;
```

Subnet No Forward

This message clears the forwarding flag in the forwarding table for a given subnet in the specified domain. If the `ram_or_eeprom` field is set, both the RAM and EEPROM flags are cleared, otherwise only the RAM flag is cleared, allowing temporary control of forwarding for a given subnet. This message is conveyed via the Request-Response protocol. The configuration checksum in EEPROM is updated if EEPROM is changed.

```
typedef struct {
    unsigned   unused1           : 1;
    unsigned   domain_index     : 1;
    unsigned   unused2           : 5;
    unsigned   ram_or_eeprom    : 1; // 0 => RAM, 1 => RAM + EEPROM
    unsigned   subnet;
} NM_rtr_subnet_nofwd_request;
```

Group or Subnet Table Report

This message is used to report the current settings of either group or subnet forwarding tables in EEPROM or RAM for the specified domain for a single router side. The report function is broken into eight byte sections. This message is conveyed via the Request-Response protocol.

WARNING: *This message is only supported by router firmware version 5 or later. Use of this message with earlier versions of the router firmware will cause the router to become inoperable.*

```

typedef struct {
    unsigned    group_or_subnet : 1; // 1 => Group, 0 => Subnet
    unsigned    domain_index    : 1;
    unsigned    ram_or_eeprom    : 1; // 0 => RAM, 1 => EEPROM
    unsigned    unused          : 3;
    unsigned    index_times_8    : 2;
} NM_rtr_table_report_request;

typedef struct {
    unsigned    table[8];          // Table data
} NM_rtr_table_report_response;

```

Router Status

This message is used to report the router configuration and flood/normal modes. This message is conveyed via the Request-Response protocol.

```

typedef enum {
    CONFIGURED = 0,
    LEARNING   = 1,
    BRIDGE     = 2,
    REPEATER   = 3
} algorithm;

typedef enum {
    NORMAL          = 0,          // Not a temporary bridge.
    INIT_RTR_TABLE = 1,          // Copy forwarding tables from EEPROM
                                // for configured routers.
                                // Initialize forwarding tables for
                                // learning routers.
    TEMP_BRIDGE    = 2,          // Temporarily a bridge until next reset.
} rtr_mode;

typedef struct {
    algorithm type;              // CONFIGURED, LEARNING, BRIDGE,
                                // or REPEATER
    rtr_mode  mode;              // TEMP_BRIDGE or NORMAL
} NM_rtr_status_response;

```

Far Side Escape Code

When this message code is placed in the message and is followed by **any** network management or network diagnostic message (except the escape message itself); that message will be passed over to the **other (far)** router side for processing. Any responses are returned in the normal manner. This allows network management of the router side which is not directly addressable from a network services tool.

The far side escape tool is not required for the *Set Node Mode* network management message when it is used to place the router offline and online (the `APPL_OFFLINE` and `APPL_ONLINE` options). The offline and online commands are automatically forwarded.

```
byte code; /* Destination: NM, code: 0x7E */
```

Router Options Set With Write Memory

The *Write Memory* network management message is used to change the routing algorithm, buffer sizes, and buffer queue counts. To change these parameters, follow these steps:

- 1 Change the parameters using the *Write Memory* network management message as described in the following sections.
- 2 Reset the router using the *Set Node Mode* network management message.

Set Routing Algorithm

The routing algorithm is selected using a *Write Memory* network management message with the following parameters:

```
mode      = CONFIG_RELATIVE (2)
offset    = 0x0037;
count     = 1;
form      = CNFG_CS_RECALC (4)
data      = routing_algorithm;
```

The *routing_algorithm* value is a byte of type `algorithm`:

```
typedef enum {
    CONFIGURED    = 0,
    LEARNING      = 1,
    BRIDGE        = 2,
    REPEATER      = 3
} algorithm;
```

Set Buffer Size

The buffer sizes are selected using a *Write Memory* network management message with the following parameters:

```
mode      = READ_ONLY_RELATIVE (1)
offset    = 0x0019;
count     = 1;
form      = BOTH_CS_RECALC (1)
data      = buffer_sizes;
```

The *buffer_sizes* value contains two nibble fields which control the size of both the input and output buffers. The output size value also controls the priority output buffer size. The default size is 66 bytes, or code (`SIZE_66 = 0xB`). When changing this value you should set both nibble fields to the same value. Different values may be used if the maximum packet size is different for the two directions through the router. The default setting for this byte is `0xBB`. The total number of bytes assigned to the buffer queues must not exceed 1254 bytes as described under *Message Buffers* in Chapter 2. A buffer size of less than 66 is

not recommended because the router will not be able to forward network management messages if the buffers are too small.

The size values are represented by a code of type `buffer_size_entry`:

```
typedef enum {
    SIZE_20 = 0x2;
    SIZE_21 = 0x3;
    SIZE_22 = 0x4;
    SIZE_24 = 0x5;
    SIZE_26 = 0x6;
    SIZE_30 = 0x7;
    SIZE_34 = 0x8;
    SIZE_42 = 0x9;
    SIZE_50 = 0xA;
    SIZE_66 = 0xB;
    SIZE_82 = 0xC;
    SIZE_114 = 0xD;
    SIZE_146 = 0xE;
    SIZE_210 = 0xF;
    SIZE_255 = 0x0;
} buffer_size_entry;
```

Set Priority Output Buffer Queue Count

The priority output buffer queue count is selected using a *Write Memory* network management message with the following parameters:

```
mode = READ_ONLY_RELATIVE (1)
offset = 0x001A;
count = 1;
form = BOTH_CS_RECALC (1)
data = queue_count;
```

The `queue_count` value contains two nibble fields. The most significant nibble controls the number of priority output buffers. The least significant nibble must be zero. The total number of bytes assigned to the buffer queues must not exceed 1254 bytes as described under *Message Buffers* in Chapter 2.

The most significant nibble of `queue_count` is represented by a code of type `queue_count_entry`:

```
typedef enum {
    COUNT_1 = 0x2;
    COUNT_2 = 0x3;
    COUNT_3 = 0x4;
    COUNT_5 = 0x5;
    COUNT_7 = 0x6;
    COUNT_11 = 0x7;
    COUNT_15 = 0x8;
    COUNT_23 = 0x9;
    COUNT_31 = 0xA;
    COUNT_47 = 0xB;
    COUNT_63 = 0xC;
} queue_count_entry;
```

Set Input and Non-Priority Output Buffer Queue Count

The buffer queue counts are selected using a *Write Memory* network management message with the following parameters:

```
mode      = READ_ONLY_RELATIVE (1)
offset    = 0x001C;
count     = 1;
form      = BOTH_CS_RECALC (1)
data      = queue_counts;
```

The *queue_counts* value contains two nibble fields which control the count of both the input and non-priority output buffer queues. The least significant nibble controls the number of input buffers and the most significant nibble controls the number of non-priority output buffers. The default for this field is 15 non-priority output buffers (COUNT_15) and 2 input buffers (COUNT_2). The total number of bytes assigned to the buffer queues must not exceed 1254 bytes as described under *Message Buffers* in Chapter 2. The queue count for both queues is represented by the source code as that for *Set Priority Output Buffer Queue Count* above.

Appendix A

Communications Parameters

LONWORKS Routers are initially programmed with communications parameters as listed in this appendix. Parameters for LONMARK-approved transceivers correspond to the parameters defined by the *LONWORKS Interoperability Guidelines*. The parameters specified as “Configurable” may be changed by a network services tool.

These parameters only apply to routers with router firmware version 5 or newer. The firmware version number for a router can be determined with the LonMaker or LonBuilder test command or with the *Query Status* network diagnostic message. The LonMaker test command is described under *Testing Devices* in Chapter 6 of the *LonMaker User’s Guide*. The LonBuilder test command is described under *Testing Routers* in Chapter 13 of the *LonBuilder User’s Guide*. The *Query Status* network diagnostic message is described in Appendix B of the Neuron data book.

Communications parameters for routers with version 4 or older firmware should be re-installed to ensure that the standard interoperable parameters are used.

Parameter	TP/XF-78	TP/XF-1250	TP/FT-10	TP/RS485-39
Transceiver ID	1 (01 hex)	3 (03 hex)	4 (04 hex)	5 (05 hex)
Media	Isolated Twisted Pair	Isolated Twisted Pair	Free Topology and Link Power	RS-485 Twisted Pair
Neuron Chip to Transceiver Interface	Differential	Differential	Single-Ended	Single-Ended
Interface Bit Rate	78kbps	1.25Mbps	78kbps	39kbps
Input Clock	5/10MHz*	10MHz	5/10MHz*	5/10MHz*
Minimum Clock	Configurable; default = 5MHz	Configurable; default = 10MHz	Configurable; default = 5MHz	Configurable; default = 5MHz
Number of Priority Slots	Configurable; default = 4 slots	Configurable; default = 16 slots	Configurable; default = 4 slots	Configurable; default = 4 slots
Average Packet Size	Configurable; default = 15 bytes	Configurable; default = 15 bytes	Configurable; default = 15 bytes	Configurable; default = 15 bytes
Oscillator Accuracy	200ppm	200ppm	200ppm	200ppm
Oscillator Wakeup	0μsec	0μsec	0μsec	0μsec
Collision Detect (CD)	No	No	No	No
CD Term after Preamble	N/A	N/A	N/A	N/A
CD Through Packet End	N/A	N/A	N/A	N/A
Bit Sync Threshold	5 bits	7 bits	4 bits	4 bits
Hysteresis	2	0	N/A	N/A
Filter	1	0	N/A	N/A
Network Bit Rate	78kbps	1.25Mbps	78kbps	39kbps
Alternate Rate	N/A	N/A	N/A	N/A
Wakeup Pin Direction	N/A	N/A	N/A	N/A
XCVR Controls Preamble	N/A	N/A	N/A	N/A
General Purpose Data	N/A	N/A	N/A	N/A
Allow Node Override	N/A	N/A	N/A	N/A
Receive Start Delay	2.9 bits	14.0 bits	9.0 bits	2.0 bits
Receive End Delay	0.0 bits	0.0 bits	0.0 bits	0.0 bits
Indeterminate Time	24.0 bits	25.0 bits	24.0 bits	4.0 bits
Min. Interpacket Time	0.0 bits	0.0 bits	0.0 bits	0.0 bits
Turnaround Time	0μsec	0μsec	0μsec	0μsec
Missed Preamble	1.0 bits	4.0 bits	4.0 bits	1.0 bits
Preamble Length	N/A	N/A	N/A	N/A
Use Raw Data	No	No	No	No

*The input clock rate is 10MHz for these transceivers on the Model 61000 RTR-10 Router Core Module; the input clock rate is 5MHz for these transceivers on the Model 71000 LONWORKS Router.

Parameter	RF-10	PL-10	PL-20C
Transceiver ID	7 (07 hex)	9 (09hex)	16 (10 hex)
Media	49MHz Radio Frequency	Power Line	Power Line
Neuron Chip to Transceiver Interface	Single-Ended	Special Purpose	Special Purpose
Interface Bit Rate	4.9kbps	625kbps	156.3kbps
Input Clock	5MHz	10MHz	10MHz
Minimum Clock	Configurable; default = 5MHz	Configurable; default = 5MHz	Configurable; default = 1.25MHz
Number of Priority Slots	Configurable; default = 4 slots	Configurable; default = 8 slots	Configurable; default = 8 slots
Average Packet Size	Configurable; default = 15 bytes	Configurable; default = 15 bytes	Configurable; default = 15 bytes
Oscillator Accuracy	200ppm	200ppm	200ppm
Oscillator Wakeup	0μsec	0μsec	0μsec
Collision Detect (CD)	No	N/A	N/A
CD Term after Preamble	N/A	N/A	N/A
CD Through Packet End	N/A	N/A	N/A
Bit Sync Threshold	7 bits	N/A	N/A
Hysteresis	N/A	N/A	N/A
Filter	N/A	N/A	N/A
Network Bit Rate	4.9kbps	9412bps	3987bps
Alternate Rate	N/A	0bps	N/A
Wakeup Pin Direction	N/A	Output	Output
XCVR Controls Preamble	N/A	Yes	Yes
General Purpose Data	N/A	00 0A 00 00 00 00 00	4A 00 00 00 00 00 00
Allow Node Override	N/A	Yes	No
Receive Start Delay	2.0 bits	1.0 bit	6.8 bits
Receive End Delay	0.0 bits	10.4 bits	1.6 bits
Indeterminate Time	9.8 bits	0.0 bits	0.0 bits
Min. Interpacket Time	0.0bits	0.0 bits	17.5 bits
Turnaround Time	0μsec	N/A	N/A
Missed Preamble	9.0 bits	N/A	N/A
Preamble Length	N/A	36.7 bits	33.5 bits
Use Raw Data	No	No	No

* The input clock rate is 10MHz for these transceivers on the Model 61000 RTR-10 Router Core Module; the input clock rate is 5MHz for these transceivers on the Model 71000 LONWORKS Router.

Parameter	PL-20N	PL-30
Transceiver ID	17 (11 hex)	18 (12 hex)
Media	Power Line	Power Line
Neuron Chip to Transceiver Interface	Special Purpose	Special Purpose
Interface Bit Rate	156.3kbps	625kbps
Input Clock	10MHz	10MHz
Minimum Clock	Configurable; default = 1.25MHz	Configurable; default = 5MHz
Number of Priority Slots	Configurable; default = 8 slots	Configurable; default = 12 slots
Average Packet Size	Configurable; default = 15 bytes	Configurable; default = 15 bytes
Oscillator Accuracy	200ppm	200ppm
Oscillator Wakeup	0μsec	0μsec
Collision Detect (CD)	N/A	N/A
CD Term after Preamble	N/A	N/A
CD Through Packet End	N/A	N/A
Bit Sync Threshold	N/A	N/A
Hysteresis	N/A	N/A
Filter	N/A	N/A
Network Bit Rate	3987bps	1882bps
Alternate Rate	N/A	N/A
Wakeup Pin Direction	Output	Output
XCVR Controls Preamble	Yes	Yes
General Purpose Data	0E 01 00 00 00 00 00	00 8A 00 00 00 00 00
Allow Node Override	No	Yes
Receive Start Delay	6.8 bits	1.0 bit
Receive End Delay	1.6 bits	10.4 bits
Indeterminate Time	0.0 bits	0.0 bits
Min. Interpacket Time	17.5 bits	0.0 bits
Turnaround Time	N/A	N/A
Missed Preamble	N/A	N/A
Preamble Length	33.5 bits	36.7 bits
Use Raw Data	No	No

*The input clock rate is 10MHz for these transceivers on the Model 61000 RTR-10 Router Core Module; the input clock rate is 5MHz for these transceivers on the Model 71000 LONWORKS Router.

Parameter	TP/RS485-625	TP/RS485-1250	TP/RS485-78
Transceiver ID	10 (0A hex)	11 (0B hex)	12 (0C hex)
Media	RS-485 Twisted Pair	RS-485 Twisted Pair	RS-485 Twisted Pair
Neuron Chip to Transceiver Interface	Single-Ended	Single-Ended	Single-Ended
Interface Bit Rate	625kbps	1.25Mbps	78kbps
Input Clock	10MHz	10MHz	10MHz
Minimum Clock	Configurable; default = 5MHz	Configurable; default = 5MHz	Configurable; default = 5MHz
Number of Priority Slots	Configurable; default = 4 slots	Configurable; default = 16 slots	Configurable; default = 4 slots
Average Packet Size	Configurable; default = 15 bytes	Configurable; default = 15 bytes	Configurable; default = 15 bytes
Oscillator Accuracy	200ppm	200ppm	200ppm
Oscillator Wakeup	0μsec	0μsec	0μsec
Collision Detect (CD)	No	No	No
CD Term after Preamble	N/A	N/A	N/A
CD Through Packet End	N/A	N/A	N/A
Bit Sync Threshold	4 bits	4 bits	4 bits
Hysteresis	N/A	N/A	N/A
Filter	N/A	N/A	N/A
Network Bit Rate	625kbps	1.25Mbps	78kbps
Alternate Rate	N/A	N/A	N/A
Wakeup Pin Direction	N/A	N/A	N/A
XCVR Controls Preamble	N/A	N/A	N/A
General Purpose Data	N/A	N/A	N/A
Allow Node Override	N/A	N/A	N/A
Receive Start Delay	2.0 bits	2.0 bits	2.0 bits
Receive End Delay	0.0 bits	0.0 bits	0.0 bits
Indeterminate Time	4.0 bits	4.0 bits	4.0 bits
Min. Interpacket Time	0.0 bits	0.0 bits	0.0 bits
Turnaround Time	0μsec	0μsec	0μsec
Missed Preamble	1.0 bit	1.0 bit	1.0 bit
Preamble Length	N/A	N/A	N/A
Use Raw Data	No	No	No

* The input clock rate is 10MHz for these transceivers on the Model 61000 RTR-10 Router Core Module; the input clock rate is 5MHz for these transceivers on the Model 71000 LONWORKS Router.

Parameter	FO-10	DC-78	DC-625	DC-1250
Transceiver ID	24 (18 hex)	27 (1B hex)	28 (1C hex)	29 (1D hex)
Media	Fiber Optic	Direct Connect	Direct Connect	Direct Connect
Neuron Chip to Transceiver Interface	Single-Ended	Differential	Differential	Differential
Interface Bit Rate	1.25Mbps	78kbps	625kbps	1.25Mbps
Input Clock	10MHz	10MHz	10MHz	10MHz
Minimum Clock	Configurable; default = 10MHz	Configurable; default = 10MHz	Configurable; default = 10MHz	Configurable; default = 10MHz
Number of Priority Slots	Configurable; default = 16 slots	Configurable; default = 0 slots	Configurable; default = 0 slots	Configurable; default = 0 slots
Average Packet Size	Configurable; default = 15 bytes	Configurable; default = 15 bytes	Configurable; default = 15 bytes	Configurable; default = 15 bytes
Oscillator Accuracy	200ppm	200ppm	200ppm	200 pm
Oscillator Wakeup	0μsec	0μsec	0μsec	0μsec
Collision Detect (CD)	Yes	No	No	No
CD Term after Preamble	Yes	N/A	N/A	N/A
CD Through Packet End	Yes	N/A	N/A	N/A
Bit Sync Threshold	4 bits	4 bits	4 bits	4 bits
Hysteresis	N/A	0	0	0
Filter	N/A	0	0	0
Network Bit Rate	1.25Mbps	78kbps	625kbps	1.25Mbps
Alternate Rate	N/A	N/A	N/A	N/A
Wakeup Pin Direction	N/A	N/A	N/A	N/A
XCVR Controls Preamble	N/A	N/A	N/A	N/A
General Purpose Data	N/A	N/A	N/A	N/A
Allow Node Override	N/A	N/A	N/A	N/A
Receive Start Delay	4.0 bits	1.0 bit	1.0 bit	1.0 bit
Receive End Delay	4.0 bits	0.0 bits	0.0 bits	0.0 bits
Indeterminate Time	4.0 bits	0.0 bits	0.0 bits	0.0 bits
Min. Interpacket Time	8.0 bits	0.0 bits	0.0 bits	0.0 bits
Turnaround Time	0μsec	0μsec	0μsec	0μsec
Missed Preamble	4.0 bits	0.0 bits	0.0 bits	0.0 bits
Preamble Length	N/A	N/A	N/A	N/A
Use Raw Data	No	No	No	No

*The input clock rate is 10MHz for these transceivers on the Model 61000 RTR-10 Router Core Module; the input clock rate is 5MHz for these transceivers on the Model 71000 LONWORKS Router.

Appendix B

Software License and Patent Agreement

Copies of the software license agreement and patent notice for the router are included in this appendix.

ATTENTION

By opening the bag and/or using the Echelon product contained in the bag, you agree to be bound by all the Terms and Conditions of the Software License Agreement below. If you do not so agree, you may return the unused Echelon product (including documentation) within 15 days to the person from whom it was acquired and receive a full refund.

SOFTWARE LICENSE AGREEMENT

LICENSE GRANT

The software incorporated in this Echelon product is proprietary to Echelon. You may use the software only on this product and only in the form in which it was delivered to you, and you may use the accompanying documentation. You may transfer the software, in the form provided to you, with the product to: (i) your customer for use with equipment sold or otherwise distributed by you, or (ii) a third party that agrees in writing to be bound to the terms of this license.

You may not (i) copy, modify or translate the software or documentation, (ii) reverse engineer, disassemble, decompile or otherwise attempt to derive source code from the software or (iii) remove any proprietary notices, labels or marks on the product, software or documentation.

Echelon retains all right, title and interest in and to the software, including copyrights. Failure to comply with the above restrictions will result in automatic termination of this license and will make available to Echelon other legal remedies.

WARRANTY DISCLAIMER

Although Echelon has tested the software, and has sought to make the documentation accurate and reliable, THE SOFTWARE AND DOCUMENTATION ARE PROVIDED TO YOU "AS IS", AND YOU ASSUME THE ENTIRE RISK OF THEIR USE. ECHELON AND ITS SUPPLIERS MAKE AND YOU RECEIVE NO WARRANTIES OR CONDITIONS, EXPRESS, IMPLIED, STATUTORY OR IN ANY COMMUNICATION WITH YOU, AND ECHELON AND ITS SUPPLIERS EXPRESSLY DISCLAIM ANY IMPLIED WARRANTIES OF MERCHANTABILITY, FITNESS FOR A PARTICULAR PURPOSE OR NONINFRINGEMENT WITH RESPECT TO THE SOFTWARE OR DOCUMENTATION. No Echelon distributors, agents or personnel are authorized to make any warranty inconsistent with this disclaimer.

From time to time, Echelon may modify the software and hardware described in the documentation, and reserves the right to do so without notifying you.

LIMITATION OF LIABILITY

IN NO EVENT WILL ECHELON OR ITS SUPPLIERS BE LIABLE FOR LOSS OF DATA, LOST PROFITS, COST OF COVER, OR OTHER SPECIAL, INCIDENTAL, PUNITIVE, CONSEQUENTIAL, OR INDIRECT DAMAGES ARISING FROM USE OF THE SOFTWARE OR ACCOMPANYING DOCUMENTATION, HOWEVER CAUSED AND ON ANY THEORY OF LIABILITY. THIS LIMITATION WILL APPLY EVEN IF ECHELON, ITS SUPPLIERS, OR AN AUTHORIZED DISTRIBUTOR HAS BEEN ADVISED OF THE POSSIBILITY OF SUCH DAMAGE. YOU ACKNOWLEDGE THAT THE PRICE PAID REFLECTS SUCH ALLOCATION OF RISK. ECHELON AND ITS SUPPLIERS BEAR NO LIABILITY FOR ANY PROGRAMS OR DATA STORED IN OR USED WITH THIS PRODUCT, INCLUDING THE COST OF RECOVERING SUCH PROGRAMS OR DATA.

GENERAL

This Agreement will be governed by the laws of the State of California. This Agreement is the entire agreement held between us and supersedes any other communications or advertising with respect to the software and accompanying documentation. If any provision of this Agreement is held invalid, the remainder of this Agreement shall continue in full force and effect. Use, duplication or disclosure by the Government is subject to restrictions as set forth in subdivision (c) (1) (ii) of the Rights in Technical Data and Computer Software clause at DFARS 252.227-7013.

PATENT NOTICE

The product(s) contained in this package incorporate intellectual property that is protected by United States Patents as well as patents registered in certain other countries. Use of the product(s) is licensed only to connect one channel of a CSMA network to another channel of a CSMA network, where both channels employ the same protocol.